

Thermo Scientific

# CO<sub>2</sub> Incubator

Vios iDx

165 / 255

## Operating instructions

50173012\_Rev. \_

February 2025

©2025 Thermo Fisher Scientific Inc. All rights reserved.

## Trademarks

Vios™ is a registered trademark of Thermo Scientific.

Thermo Scientific is a trademark of Thermo Fisher Scientific Inc.

All other trademarks mentioned in this manual are the exclusive property of their respective owners.



Thermo Electron LED GmbH  
Robert-Bosch-Straße 1  
D-63505 Langenselbold  
Germany

Thermo Electron LED GmbH is a subsidiary of:

Thermo Fisher Scientific Inc.

168 3rd Avenue

Waltham, MA 02451

USA

UK importer

Life Technologies, 3 Fountain Drive

Inchinnan Business Park

PA4 9RF

Scotland

Thermo Fisher Scientific, Inc. provides this document to its customers for the purpose of device operation after the purchase of a product. These operating instructions are protected by copyright. Reproduction of this document - even in part - without the written permission of Thermo Fisher Scientific Inc. is prohibited.

The contents of the operating instructions are subject to change without notice. All information contained in this document is for information purposes only and is not binding. The system configurations and technical data contained in this document supersede all previous information received by the customer.

Thermo Fisher Scientific Inc. makes no claim that this document is complete, accurate, or free of errors and is not liable for any errors or omissions in it or for any damage resulting from the use of this document, even if the intention of such use is to follow the instructions contained in this document.

This document is not part of any sales contract between Thermo Fisher Scientific Inc. and a purchaser. This document does not affect in any way the general conditions of sale; rather, the general conditions of sale shall take precedence in all cases in which the details provided in the documents conflict.

# Table of Contents

<b>Chapter 0 Preface</b> .....	<b>0-1</b>
General notes .....	0-1
Personnel requirements.....	0-2
Operating personnel .....	0-2
Service personnel .....	0-2
Features of the device and device documentation .....	0-3
Device identification .....	0-3
Responsibility of the operator .....	0-3
Instructing the personnel .....	0-4
Applicability of the instructions.....	0-4
Warranty .....	0-5
Explanation of safety information and symbols .....	0-6
Safety information and symbols used in the operating instructions .....	0-6
Additional symbols for safety information .....	0-6
Symbols on the device .....	0-8
Intended Use .....	0-9
Standards and directives .....	0-10
Safety notes on gases .....	0-11
Safety notes on carbon dioxide (CO <sub>2</sub> ) .....	0-11
Safety notes on oxygen (O <sub>2</sub> ) .....	0-11
Safety notes on nitrogen (N <sub>2</sub> ) .....	0-12
<b>Chapter 1 Delivery of the device</b> .....	<b>1-1</b>
Packaging.....	1-1
Delivery inspection.....	1-1
Scope of delivery Vios iDx 165/255 .....	1-2
Standard equipment Vios iDx 165/255 .....	1-2
Additional equipment Vios iDx 165/255 .....	1-2
Additional equipment for Vios iDx 255 .....	1-3
<b>Chapter 2 Installation</b> .....	<b>2-1</b>
Environmental conditions.....	2-1
Requirements .....	2-1
Room ventilation .....	2-2
Space requirements.....	2-3
Transport .....	2-4
Stacking devices.....	2-5
Stacking variants .....	2-9
Installing casters on the base frame .....	2-9
Installing casters and feet on the base frame .....	2-10

Retrofitting/modifications .....	2-13
<b>Chapter 3 Description of the device .....</b>	<b>3-1</b>
Vios iDx 165/255 Front view .....	3-2
Vios iDx 165/255 Rear view.....	3-4
Safety devices Vios iDx 165/255 .....	3-5
Workspace atmosphere.....	3-6
Temperature .....	3-6
Relative humidity .....	3-6
Water quality recommendation .....	3-6
Pre-filter .....	3-7
HEPA filter and air duct .....	3-7
Gas supply .....	3-9
Door switch .....	3-10
Sensors.....	3-11
Supply interface .....	3-13
Standard interfaces .....	3-13
Optional interfaces .....	3-14
Gas connections .....	3-15
Label .....	3-15
USB interface .....	3-15
4-20 mA Interface .....	3-15
Alarm contact .....	3-17
Power connection .....	3-17
Workspace components .....	3-18
Inner chamber .....	3-18
Glass door and optional segmented inner door .....	3-19
Water reservoir .....	3-20
Heating system .....	3-22
Rear panel openings .....	3-22
Shelf system .....	3-23
Electromechanical door lock kit .....	3-24
<b>Chapter 4 Start-up .....</b>	<b>4-1</b>
Acclimatizing the device .....	4-2
Preparing the workspace .....	4-2
Installing the “MAX” fill level Indicator and the pre-filter.....	4-3
Air duct.....	4-4
Components of the air duct .....	4-4
Installation of the air duct .....	4-4
Installing the HEPA filter and water reservoir cover .....	4-5
Installing the shelf system.....	4-7
Installation/removal of the support rails .....	4-7
Installing the support brackets .....	4-8
Leveling the device .....	4-9
Vios iDx 255 split insert shelves (optional) .....	4-9
Connecting the gas.....	4-10
Installing gas pressure hoses .....	4-10

Gas connection .....	4-12
Power connection .....	4-13
Connecting the USB interface.....	4-14
Connecting the alarm contact .....	4-14
Alarm relay .....	4-14
Connecting the 4-20 mA interface .....	4-17
<b>Chapter 5 Operation .....</b>	<b>5-1</b>
Preparing the device .....	5-1
Device check .....	5-1
Decontaminating the device workspace .....	5-2
Starting operation.....	5-3
Starting the device .....	5-6
Loading the device .....	5-6
<b>Chapter 6 Handling.....</b>	<b>6-1</b>
Power switch.....	6-2
Operating panel and operating screen layout .....	6-3
Explanation of icons .....	6-4
Default settings of the controls.....	6-5
Heating phase of the control loop sensors.....	6-5
Behavior of keys in settings .....	6-6
Setting the temperature set value .....	6-7
Adjusting the CO <sub>2</sub> set value .....	6-7
Adjusting the O <sub>2</sub> set value .....	6-8
Adjusting humidity .....	6-10
Auto-start function .....	6-11
Activating auto-start .....	6-11
Launching Steri-Run .....	6-14
User configuration .....	6-15
Options .....	6-16
Trend .....	6-23
Data logging .....	6-23
Settings .....	6-28
Keypad lock .....	6-44
Software versions .....	6-44
Error messages.....	6-46
Response to an error message event .....	6-47
Resetting overtemperature protection .....	6-49
Action after power failure .....	6-49
Overview of causes of errors and troubleshooting .....	6-51
<b>Chapter 7 Shutdown .....</b>	<b>7-1</b>
Shutting the device down.....	7-1
<b>Chapter 8 Cleaning and disinfection.....</b>	<b>8-1</b>
Cleaning.....	8-1
Cleaning exterior surfaces: .....	8-1
Cleaning the display: .....	8-2

## Table of Contents

Decontamination procedures .....	8-2
Recommended disinfectants .....	8-2
Wipe/spray disinfection .....	8-2
Steri-Run sterilization cycle .....	8-5
<b>Chapter 9 Maintenance .....</b>	<b>9-1</b>
Inspections and checks .....	9-1
Daily check .....	9-1
Annual inspection .....	9-2
Maintenance intervals .....	9-2
Monthly maintenance .....	9-2
Quarterly maintenance .....	9-2
Semi-annual maintenance .....	9-2
Annual maintenance .....	9-2
Temperature calibration .....	9-3
Preparing the temperature calibration .....	9-3
Conducting the comparison measurement .....	9-4
Performing the temperature calibration .....	9-5
CO2 calibration .....	9-7
Preparing CO2 calibration .....	9-7
Conducting the comparison measurement .....	9-7
Performing CO2 calibration .....	9-8
Replacing the HEPA filter .....	9-10
Replacing the gas intake filter .....	9-12
Gas intake filter of the gas supply .....	9-12
All gas intake filters .....	9-12
Replacing the device fuses .....	9-13
Replacing the door seal .....	9-13
<b>Chapter 10 Disposal .....</b>	<b>10-1</b>
Overview of the materials used .....	10-2
<b>Chapter 11 Specifications .....</b>	<b>11-1</b>
Vios iDx 165 .....	11-2
Vios iDx 165 .....	11-4
Vios iDx 255 .....	11-6
Vios iDx 255 .....	11-8
<b>Chapter 12 Data communication .....</b>	<b>12-1</b>
USB interface .....	12-1
Installing the USB interface driver .....	12-2
Structure of the command sequences for data communication .....	12-4
Description of the protocol .....	12-4
Overview of general parameters (Addresses 0xxx) .....	12-5
Reading general parameters .....	12-6
Overview of incubator parameters (Addresses 2xxx) .....	12-6
Reading basic parameters .....	12-6
Reading internal function parameters .....	12-7
Error memory structure .....	12-8

Error memory data set structure scheme .....	12-9
Overview of the possible error messages in hex coding .....	12-11
Overview of the possible error messages in bit coding	
General device Status, temperature and CO2 control loop .....	12-11
O2 and water level control loop: .....	12-12
Data logger structure .....	12-12
Data logger data set structure scheme .....	12-14
Overview of possible event entries in bit coding	
Overview of event entries, part I: .....	12-15
Overview of event entries, part II: .....	12-16
Examples of data logger codes.....	12-16
Functions for data logger query .....	12-16
Example of a code for a data logger query .....	12-17
Vios iDx 165/255 program .....	12-22
Installing Vios iDx 165/255 .....	12-23
Using Vios iDx 165/255 .....	12-24
<b>Chapter 13 Device Log .....</b>	<b>13-1</b>
<b>Chapter 14 Thermo Scientific Contact Information .....</b>	<b>14-1</b>
<b>Chapter 14 Appendix .....</b>	<b>14-1</b>
Sixfold segmented inner door for Cell Locker .....	14-1
Installing the insert shelves .....	14-2

## List of figures

Figure 2-1. Device measurements (All dimensions in mm) .....	2-3
Figure 2-2. Lifting points .....	2-4
Figure 2-3. Stacking devices.....	2-6
Figure 2-4. Stacking frame and base frame with stacking elements .....	2-6
Figure 2-5. Screwing the adapter plate to the lower device .....	2-7
Figure 2-6. Removing the screws for the support frames .....	2-7
Figure 2-7. Mounting the support frames.....	2-8
Figure 2-8. Base frame with casters, without feet (Vios iDx 165 version).....	2-9
Figure 2-9. Base frame with casters and feet .....	2-11
Figure 2-10. Screws on the rear of the device .....	2-11
Figure 2-11. Adjusting the feet.....	2-12
Figure 3-1. Vios iDx 165/255 Front view.....	3-2
Figure 3-2. Vios iDx 165/255 Rear view .....	3-4
Figure 3-3. HEPA filter and airbox .....	3-8
Figure 3-4. Air duct .....	3-8
Figure 3-5. Door switch.....	3-10
Figure 3-6. Temperature, O <sub>2</sub> , CO <sub>2</sub> , and humidity sensors.....	3-11
Figure 3-7. Water level sensor.....	3-12
Figure 3-8. Device interfaces (right side of control box) .....	3-13
Figure 3-9. Optional device interfaces (left side of control box).....	3-14
Figure 3-10. Vios iDx 165/255 with glass door .....	3-19
Figure 3-11. Vios iDx 165 with three-segment inner door.....	3-20
Figure 3-12. Water reservoir .....	3-21
Figure 3-13. Fill and drain valve of the water reservoir .....	3-21
Figure 3-14. Rear panel openings .....	3-22
Figure 3-15. Shelf system components .....	3-23
Figure 3-16. Door lock lever and emergency release .....	3-24
Figure 4-1. “MAX” fill level indicator .....	4-3
Figure 4-2. “MAX” Fill Level Indicator and pre-filter .....	4-3
Figure 4-3. Air duct parts Vios iDx 165/255 .....	4-4
Figure 4-4. Assembling the air duct .....	4-5
Figure 4-5. Assembling the HEPA filter and the airbox.....	4-5
Figure 4-6. Mounting the airbox on the water reservoir cover .....	4-6

## List of figures

Figure 4-7. Installing the airbox.....	4-6
Figure 4-8. Shelf system installation/removal .....	4-7
Figure 4-9. Installing the support brackets .....	4-8
Figure 4-10. Installation of split shelves .....	4-9
Figure 4-11. Installing gas pressure hoses .....	4-11
Figure 4-12. Gas connection.....	4-12
Figure 4-13. Power connection .....	4-13
Figure 4-14. Example of alarm contact connection.....	4-16
Figure 4-15. Pin-out of the 4-20 mA interface .....	4-17
Figure 5-1. Water reservoir .....	5-4
Figure 5-2. Incubator fill and drain valve.....	5-5
Figure 5-3. "MAX" fill level indicator .....	5-5
Figure 6-1. Power switch .....	6-2
Figure 6-2. Start screen: Touch-sensitive screen areas .....	6-3
Figure 6-3. Explanation of icons .....	6-4
Figure 6-4. Temperature selection menu.....	6-7
Figure 6-5. CO <sub>2</sub> selection menu .....	6-8
Figure 6-6. O <sub>2</sub> selection menu.....	6-9
Figure 6-7. "Humidity mode" menu .....	6-10
Figure 6-8. Activating auto-start.....	6-12
Figure 6-9. Auto-start status display .....	6-13
Figure 6-10. Aborting auto-start .....	6-14
Figure 6-11. User configuration menu .....	6-15
Figure 6-12. Options selection menu .....	6-16
Figure 6-13. Switching water sensor on/off.....	6-17
Figure 6-14. HEPA configuration menu .....	6-19
Figure 6-15. Door configuration menu .....	6-21
Figure 6-16. O <sub>2</sub> configuration menu .....	6-22
Figure 6-17. "Trend" graphic overview .....	6-23
Figure 6-18. Data logging menu .....	6-24
Figure 6-19. Displaying events .....	6-25
Figure 6-20. Viewing the error table.....	6-26
Figure 6-21. Reminder list display .....	6-27
Figure 6-22. Settings menu.....	6-28
Figure 6-23. Changing the keypad lock code .....	6-29
Figure 6-24. Display selection menu.....	6-31
Figure 6-25. Adjusting display brightness .....	6-32
Figure 6-26. Setting the language.....	6-33
Figure 6-27. Date/time selection menu .....	6-34
Figure 6-28. Setting the time.....	6-35

Figure 6-29. Key tone selection menu .....	6-36
Figure 6-30. Alarm selection menu .....	6-37
Figure 6-31. Setting the alarm relay .....	6-38
Figure 6-32. Reminder interval menu .....	6-40
Figure 6-33. Setting the reminder interval for Steri-Run .....	6-40
Figure 6-34. Logging cycle selection menu .....	6-43
Figure 6-35. Keypad lock input dialog .....	6-44
Figure 6-36. Software versions menu .....	6-45
Figure 6-37. Device door open .....	6-46
Figure 6-38. System error Door open too long .....	6-47
Figure 6-39. Example of temperature error message .....	6-48
Figure 6-40. Temp alarm screen .....	6-48
Figure 7-1. Fill and drain valve of the water reservoir .....	7-1
Figure 8-1. HEPA filter and airbox .....	8-4
Figure 8-2. Air duct .....	8-5
Figure 8-3. Fill and drain valve of the water reservoir .....	8-6
Figure 8-4. Phases of the Steri-Run sterilization cycle .....	8-9
Figure 8-5. Steri-Run menu .....	8-10
Figure 8-6. Steri-Run cycle .....	8-11
Figure 8-7. Steri-Run cancellation .....	8-12
Figure 8-8. Ending Steri-Run .....	8-13
Figure 8-9. Emergency release on the underside of the incubator .....	8-14
Figure 9-1. Preparing the temperature calibration .....	9-3
Figure 9-2. Temperature selection menu .....	9-5
Figure 9-3. Performing the temperature calibration .....	9-6
Figure 9-4. Measurement opening in a segmented inner door .....	9-8
Figure 9-5. CO2 selection menu .....	9-9
Figure 9-6. Performing CO2 calibration .....	9-10
Figure 9-7. Removing the airbox .....	9-11
Figure 9-8. Installing the HEPA filter .....	9-11
Figure 9-9. Gas intake filter installation .....	9-12
Figure 12-41. Device manager .....	12-2
Figure 12-42. Installing the USB interface driver - 1 .....	12-2
Figure 12-43. Installing the USB interface driver - 2 .....	12-3
Figure 12-44. Installing the USB interface driver - 3 .....	12-3
Figure 12-45. Installing the USB interface driver - 4 .....	12-4
Figure 12-46. Error memory data set structure .....	12-10
Figure 12-47. Data logger data set structure .....	12-14
Figure 12-48. Vios iDx 165/255 program .....	12-22
Figure 12-49. Installing Vios iDx 165/255 program - 1 .....	12-23

## List of figures

Figure 12-50. Installing Vios iDx 165/255 program - 2.....	12-23
Figure 12-51. Vios iDx 165/255 user interface - 1 .....	12-24
Figure 12-52. Vios iDx 165/255 user interface - 2 .....	12-25
Figure 12-53. Vios iDx 165/255 user interface - 3 .....	12-26
Figure 12-54. Vios iDx 165/255 user interface - 4 .....	12-26
Figure 12-55. Vios iDx 165/255 user interface - 5 .....	12-27
Figure 12-56. Vios iDx 165/255 user interface - 6 .....	12-27
Figure 12-57. Vios iDx 165/255 user interface - 7 .....	12-28
Figure 12-58. Vios iDx 165/255 user interface - 8 .....	12-29
Figure 14-1. Sixfold segmented inner door for Cell Locker.....	14-1
Figure 14-2. Inserting the support brackets .....	14-2
Figure 14-3. Perforated shelf with continuous guide rails .....	14-2
Figure 14-4. Perforated shelf with divided guide rails (below) .....	14-3
Figure 14-5. Installing the perforated metal shelf.....	14-3

# Preface

## General notes

These operating instructions describe the CO<sub>2</sub> incubators Vios iDx 165/255. The CO<sub>2</sub> incubators were manufactured according to the state of the art in technology and were tested for functionality before delivery.

However, these devices may be hazardous. Especially if they are not operated by sufficiently trained personnel, or if they are used improperly and not as intended.

Therefore, the following should be observed to prevent accidents:

The equipment may only be operated by operating personnel and may only be maintained and repaired by trained personnel. Personnel must know and understand the contents of this manual before working on or with the devices.

Safety instructions on the devices must be kept in a legible condition and may not be removed.

Keep these operating instructions close to the device so that safety instructions and information for operation can be consulted at all times.

If individual topics in these operating instructions have not been sufficiently covered, please contact Thermo Fisher Scientific for your own safety.

The device may only be operated using original replacement parts and original accessories.

Occupational safety regulations must be observed without fail!

# Personnel requirements



## **CAUTION**

Persons who are still in training or have not yet completed their training in the handling of the device may only work on the device under the constant supervision of an experienced person.

## **Operating personnel**

### **Trained specialist personnel**

Trained experts are persons who have suitable technical training and/or many years of experience in the relevant field of work. Based on their knowledge and experience, they are able to recognize and avoid hazards arising from laboratory equipment. They meet the country-specific requirements regarding compliance with a minimum age.

### **Instructed users**

Instructed users are untrained and inexperienced persons who were instructed by trained specialist personnel so that they can avoid dangers arising from the device.

## **Service personnel**

### **Trained personnel**

Trained personnel are persons trained by Thermo Scientific in the use of the device and are authorized to repair, service, and maintain the device.

### **Qualified electricians**

Qualified electricians are persons who, due to their training and professional experience, know and can avoid all risks and dangers posed by laboratory equipment and can also avoid all risks to the device itself to the extent possible.

# Features of the device and device documentation

## Device identification

### Device identification

Device name: CO<sub>2</sub> incubators  
Name of device: Vios iDx 165/255

### Certification and quality audit:

Conformity: CE marking  
Certification mark: cTÜVus

## Responsibility of the operator

The operator is responsible for the proper condition of the device. In particular, the following must be ensured:

- the device is in perfect condition before being put into service.
- the device is used properly and for its intended purpose.
- the performance of the products is appropriate to the client's specific use or application.
- the incubator is only operated by the operating personnel.
- these personnel always wear the required protective equipment when working on or with the device.
- if hazardous substances are spilled on or in the incubator, appropriate remedial action will be taken.
- (s)he is aware of all rules and regulations and passes these on to the staff.
- written procedures will be established for personnel working with this device.

These must be based on:

- these operating instructions
- the valid safety data sheets
- the company's hygiene guidelines
- the relevant technical regulations

In particular, this includes operating instructions:

- which disinfection measures should be applied for the device and the accessories used,
- what safety measures are to be taken during the processing of certain working materials,
- wearing protective equipment, e.g. when handling microbiological and biological cultures,

## **Preface**

### Instructing the personnel

- what safety measures are to be taken when gases and pressurized gas containers are used,
- what action is to be taken in the event of accidents,
- what safety measures and rules of conduct are necessary when entering and working in a clean room.
- that repair work on the device is only carried out by trained personnel who, in particular, have knowledge of the handling of gases and gas containers.
- that the specified maintenance intervals are observed.
- that the device is only operated in a clean, tidy, and suitable environment.
- that it is ensured that unauthorized persons do not have access to the device.

## **Instructing the personnel**

Personnel who work on systems involving a CO<sub>2</sub> supply must be instructed in the special handling of CO<sub>2</sub> before starting work:

- the proper operation of pressurized gas containers and gas supply systems
- the obligation to report damage to and defects in the CO<sub>2</sub> feed lines
- Action to be taken in the event of accidents and malfunctions

The instructions must be repeated at appropriate intervals. The gas supplier's specific operating instructions should be included in the instructions.

## **Applicability of the instructions**

- The contents of these operating instructions are subject to change at any time without notice.
- In the case of conflicting translations into foreign languages, the German language version of these operating instructions is binding.
- Keep these operating instructions close to the device so that safety instructions and information important for operation can be consulted at all times.

Should you encounter questions that have not been covered in sufficient detail in these operating instructions, contact Thermo Scientific for your own safety.

## Warranty

- Thermo Scientific warrants the safety and functionality of the CO<sub>2</sub> incubator (for 2 years) only on condition that:
- the device is operated and serviced exclusively in accordance with its intended purpose and as described in these operating instructions,
- the device is not modified,
- only original spare parts and accessories approved by Thermo Fisher Scientific are used,
- inspections and maintenance work are performed at the specified intervals.

The Cell Locker and all accessories have a one year warranty. The warranty period begins with the delivery of the device to the orderer.

# Explanation of safety information and symbols

## Safety information and symbols used in the operating instructions



**DANGER** Indicates a hazardous situation which, if not avoided, could result in death or serious injury.



**WARNING** Indicates a hazardous situation which, if not avoided, could result in minor or moderate injury.



**CAUTION** Indicates a situation which, if not avoided, could result in property damage.

**Note** Provides application tips and useful information.

## Additional symbols for safety information



Wear safety gloves!



Wear safety goggles!



Wear a mask!



Pull out the mains plug!



Read the operating instructions!



Tilting hazard!



Crushing hazard!



Bio Hazard!



Environmental pollution!



Lift the device with at least 4 persons!



The device is heavy! Do not lift alone!



Lift with mechanical aids!



Take care to handle gas correctly!



Hazardous liquids!



Electric shock!



Hot surfaces!



Fire hazard!

## Preface

Explanation of safety information and symbols



Explosion hazard!



Suffocation hazard!

## Symbols on the device



CE marking: confirms conformity to EU guidelines



Mark of conformity for USA/Canada



Observe operating instructions!



Hot surfaces!

## Intended Use



### DANGER

Do not use cell or tissue cultures in the device that are not in accordance with the regulations of safety levels L1, L2, and L3. It is not permissible to use substances or liquids as cultures that:

- are easily ignitable or explosive,
- release vapors that form combustible or explosive mixtures when exposed to air,
- release poisons.

The Cell Lockers are not for use in medical devices.

This CO<sub>2</sub> incubator is designed for preparing and cultivating cell cultures, but is not to be used for medical applications or for in-vitro diagnostics. To that end, controlled physiological ambient conditions are produced in the device workspace by exerting precise control of the following parameters:

- Temperature
- CO<sub>2</sub> content
- O<sub>2</sub>/N<sub>2</sub> content
- Relative humidity

Typically, the CO<sub>2</sub> incubator was developed for installation and operation in the following areas of application:

- Laboratories for cytobiological and biotechnological experiments of safety levels L1, L2, and L3
- Medical-microbiological laboratories in accordance with DIN EN 12128
- Research labs in clinics and hospitals

This device is designed for professional use only and may only be operated by trained specialist personnel.

## Standards and directives

The device complies with the following standards and directives:

- Low voltage directive 2014/35/EU
- IEC 61010-1:2020 / AMD1:2016, Safety requirements for electrical equipment for instrumentation and control and laboratory use - Part 1: General requirements
- IEC 61010-2-010:2019, Safety requirements for electrical equipment for instrumentation and control and laboratory use - Part 2-010: Particular requirements for laboratory equipment for the heating of materials
- EMC Directive 2014/30/EU
- IEC 61326-1:2020, Electrical equipment for instrumentation and control and laboratory use - EMC requirements, Part 1: General requirements

In other countries, the corresponding national regulations are binding.

### **Note**

#### US (FCC)

This equipment has been tested and found to comply with the limits for a Class A digital device, pursuant to part 15 of the FCC Rules. These limits are designed to provide reasonable protection against harmful interference when the equipment is operated in a commercial environment. This equipment generates, uses, and can radiate radio frequency energy and, if not installed and used in accordance with the instruction manual, may cause harmful interference to radio communications. Operation of this equipment in a residential area is likely to cause harmful interference in which case the user will be required to correct the interference at his own expense.”

#### Canada (ICES-001)

“This ISM device complies with Canadian ICES-001. Cet appareil ISM est conforme à la norme NMB-001 du Canada.”

## Safety notes on gases

### DANGER



Installation work:

Work on supply lines and pressurized gas containers, cylinders, or collecting containers, in which CO<sub>2</sub> and/or O<sub>2</sub>/N<sub>2</sub> are kept may only be carried out by specialist personnel using the appropriate tools.

### WARNING



Ensure that the occupational exposure limits for CO<sub>2</sub> and/or O<sub>2</sub>/N<sub>2</sub> are not exceeded.

For the Federal Republic of Germany, it is recommended that the TRGS 900 be observed; other countries may have different limit values. The country-specific national workplace exposure limits must be adhered to.

## Safety notes on carbon dioxide (CO<sub>2</sub>)

CO<sub>2</sub> is classified as a hazardous gas. Therefore, when putting the CO<sub>2</sub> incubator into service and while using it, the following safety measures must be observed:

### DANGER



Suffocation hazard!

If large amounts of carbon dioxide (CO<sub>2</sub>) are released into the room atmosphere, there is a risk of suffocation.

If CO<sub>2</sub> leaks, take safety measures immediately!



- Leave the room immediately and secure the entrances!
- Inform the security service or fire department!

## Safety notes on oxygen (O<sub>2</sub>)

O<sub>2</sub> is a gas that promotes combustion and may explode in combination with grease-containing materials.

### DANGER



Oxygen explosion!

Oxygen (O<sub>2</sub>) explodes in combination with oils, greases, and lubricants. If highly compressed oxygen comes into contact with grease- or oil-containing substances, there is a risk of explosion!



- To clean these device parts, use only oil- and fat-free cleaning agents.
- Keep all connections and components of the oxygen system free of substances that contain oil, grease, or lubricant!



**DANGER**

Fire hazard!

Leaking oxygen (O<sub>2</sub>) is extremely combustion-promoting. Do not use open flames in the vicinity of oxygen-supplying systems!



- Do not smoke near the oxygen system!
- Do not subject the oxygen system components to strong heat.

## Safety notes on nitrogen (N<sub>2</sub>)

Nitrogen mixes readily with air. High concentrations of nitrogen reduce the oxygen content of the air.



**DANGER**

Suffocation hazard!

If large amounts of nitrogen (N<sub>2</sub>) are released into the room atmosphere, there is a risk of suffocation.

If N<sub>2</sub> leaks, take safety measures immediately!



- Leave the room immediately and secure the entrances!
- Inform the security service or fire department!

# Delivery of the device

## Contents

- "Packaging" on Page 1-1
- "Delivery inspection" on Page 1-1
- "Scope of delivery Vios iDx 165/255" on Page 1-2

## Packaging

The CO<sub>2</sub> incubators Vios iDx 165/255 are delivered in a stable packing crate. All packaging materials can be separated and are reusable:

- Packing box: recycled paper
- Plastic foam: polyethylene
- Packing film: polyethylene
- Packing tapes: polypropylene
- Feet: polypropylene
- Pallet: untreated wood

## Delivery inspection

Upon delivery, immediately check:

- completeness of the delivery,
- condition of the device on delivery.

If components are missing or damage from transport is found on the device or the packaging, especially damage caused by humidity and water, contact the carrier as well as technical support immediately.

## Scope of delivery Vios iDx 165/255

### Standard equipment Vios iDx 165/255

Device components supplied	Number of items
Water reservoir cover panel	1
Max. water level sensor	1
Rear wall air duct	1
Air duct, top	1
Airbox incl. seal	1
Pre-filter	1
Insert shelves	3
Support rails for shelves	4
Support bracket for shelves	6
Plug for access port	1
Power cable	1
CO <sub>2</sub> connecting hose set	1
Operating instructions	1
Quick-release connector with hose for water drain	1

### Additional equipment Vios iDx 165/255

Components	Number of items
<b>Oxygen regulation</b>	
O <sub>2</sub> sensor head	1
O <sub>2</sub> connecting hose set	1
<b>Filters</b>	
HEPA filter	1
<b>Interface 4...20 mA</b>	
Plug 4...20mA	1
Threefold segmented inner door	1
Sixfold segmented inner door	1
Cell Locker	6
Filling cylinder	1

## **Additional equipment for Vios iDx 255**

<b>255 L devices with divided shelves</b>	<b>Number of items</b>
Support frame	3
Divided shelves	6

# Installation

## Contents

- "Environmental conditions" on Page 2-1
- "Room ventilation" on Page 2-2
- "Space requirements" on Page 2-3
- "Transport" on Page 2-4
- "Stacking devices" on Page 2-5
- "Retrofitting/modifications" on Page 2-13

## Environmental conditions

The device must only be operated at locations that meet the particular environmental conditions listed below:

### Requirements

- Draft-free and dry location.
- The minimum distances from adjacent areas on all sides must be maintained, see "Space requirements" on Page 2-3.
- The operating room must be equipped with appropriate room ventilation.
- Solid, level, non-combustible surface.
- In addition, use a stable, vibration-proof substructure (base frame, lab table) capable of bearing the weight of the device and of accessories (particularly if several devices are stacked).
- The device is designed for operation at one location at a maximum of 2000 m above sea level.
- To ensure a constant incubation temperature of 37°C (98.6 °F), the ambient temperature must be within a range of +18°C to +34°C (+ 64.4 °F to + 93.2 °F).
- Relative humidity up to max. 80%.
- No direct exposure to sunlight.

- Devices that generate high amounts of heat must not be installed or placed near the **Vios iDx 165/255**.

## Room ventilation

When CO<sub>2</sub>/O<sub>2</sub>/N<sub>2</sub> is supplied, the incubator workspace of the incubator is slightly pressurized. The pressure is released through the pressure compensation opening into the operating room.

Pressure compensation and opening of the glass door/segmented inner door during the operation of the device will release very small quantities of CO<sub>2</sub>/O<sub>2</sub>/N<sub>2</sub> into the operating room. The room ventilation must be capable of carrying off the released gas safely into the open.

In addition, heat dissipating from the device during continuous operation may cause a change in the room climate.

- Deploy the **Vios iDx 165/255** only in adequately ventilated rooms.
- Do not set up the device in unventilated alcoves.
- The room ventilation should be technical ventilation that complies with the national requirements for laboratories or a ventilation system with equivalent performance.

## Space requirements



### WARNING

#### EMERGENCY STOP!

The mains socket must be accessible at all times in case of the need for an EMERGENCY STOP. The mains plug must be easily identifiable by the user and freely accessible at all times.

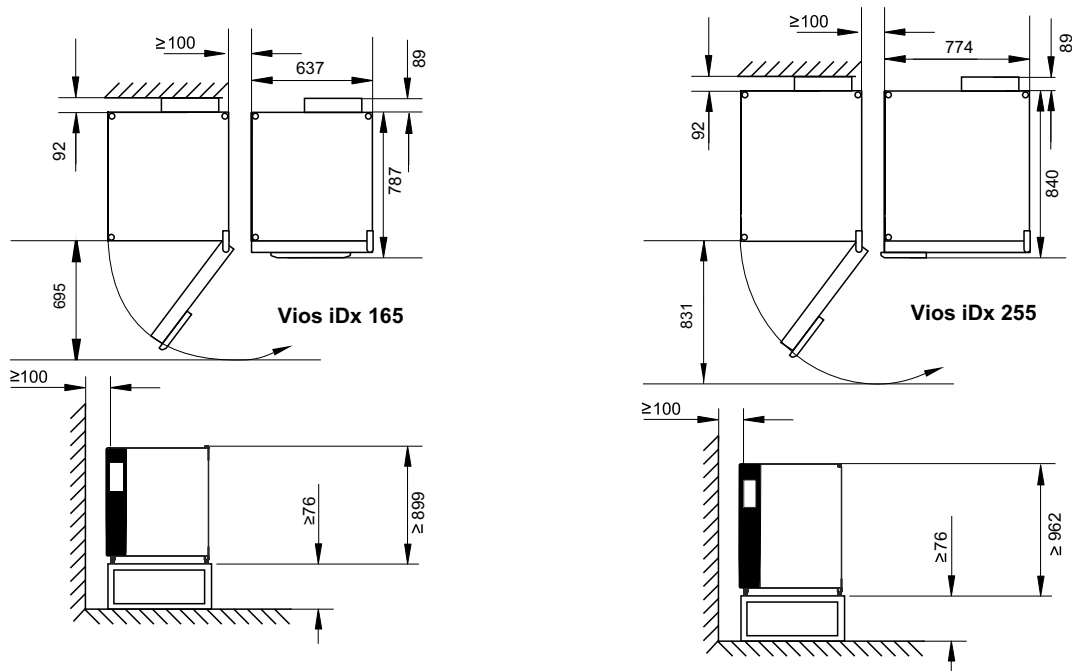

**Figure 2-1.** Device measurements (All dimensions in mm)

### Note

Accessibility of the devices:

To ensure better accessibility for care and maintenance work, it is recommended to keep larger side and rear distances. In order to swing out the door, there must be a distance of ≥31 cm / 12.2" from the wall on the door hinge side of devices with a six-segment inner door and Cell Locker.

## Transport

### WARNING

Heavy loads! Lifting hazard!

- Never attempt to lift the incubator alone! This could result in strain injuries, such as sprains and intervertebral disc lesions.
- When lifting the incubator, always wear personal protective equipment such as safety shoes.
- To avoid crushing fingers or hands (particularly when closing the door) or damaging the incubator, do not use any lifting points other than those indicated in the figure below.



### CAUTION

Lifting points:

- Only load the device at the lifting points marked in the figure.
- Do not lift the device by the doors or attached parts, such as the rear switch box.

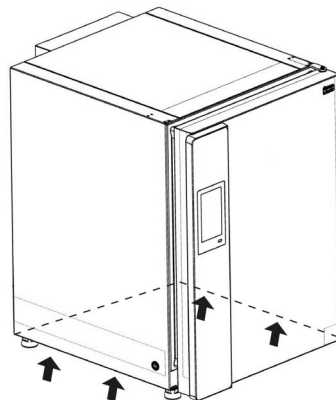

Figure 2-2. Lifting points

## Stacking devices

### WARNING

Risk of tilting and falling of stacked devices!



To avoid the risk of tilting of the device, the support frame must be mounted on a wall of the building that is capable of bearing the load of the stacked devices. The installation must be carried out by qualified personnel only. To attach the support frame to the building structure, use appropriate screws and wall plugs with a load rating of at least 25 kg.

### CAUTION

Moving stacked devices:

- Before moving stacked devices, be sure to remove the support frames!
- Only move stacked devices on a mobile base frame in rooms with an even floor without slopes.



### CAUTION

- When installing the stacking adapter plate and stacking the devices, follow the assembly instructions included with the stacking adapter.



### CAUTION

Transporting stacked devices!

Stacking elements are not connection elements. Stacked devices on a mobile base frame may only be moved inside rooms on even floors without any slopes.



### CAUTION

Fastening on mobile base frames:

If you place the devices on mobile base frames, you must ensure that the casters are locked with a parking brake during operation of the incubators and that the casters are facing forwards for greater stability.



### CAUTION

#### Condensate formation during the operation of stacked devices

In general, when operating stacked devices of the **Vios iDx 165/255** type, an adapter plate must be used as thermal separation. If stacked devices are operated at an ambient temperature of more than 28°C (82.4 °F), an overtemperature alarm is triggered on the upper device while the Steri-run sterilization cycle is running on the lower device. Condensate formation may then occur on the upper device.



The Vios iDx 165/255 devices are suitable for stacking a maximum of two devices of the same device type. For this purpose, an optional stacking adapter ([Figure 2-3, 1](#)) is used between the two devices.

Optionally, a mobile base frame ([Figure 2-3, 2](#)) is available for moving the devices.

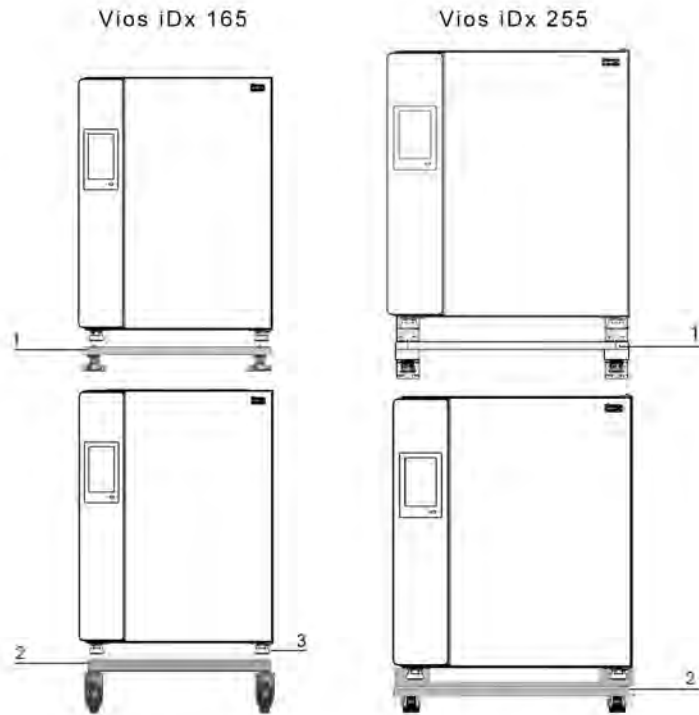

**Figure 2-3.** Stacking devices

1. Place the lower device with the device feet (Figure 2-3, 3) on the stacking elements (Figure 2-4, 1) or on the top of the mobile base frame (Figure 2-4, 2).

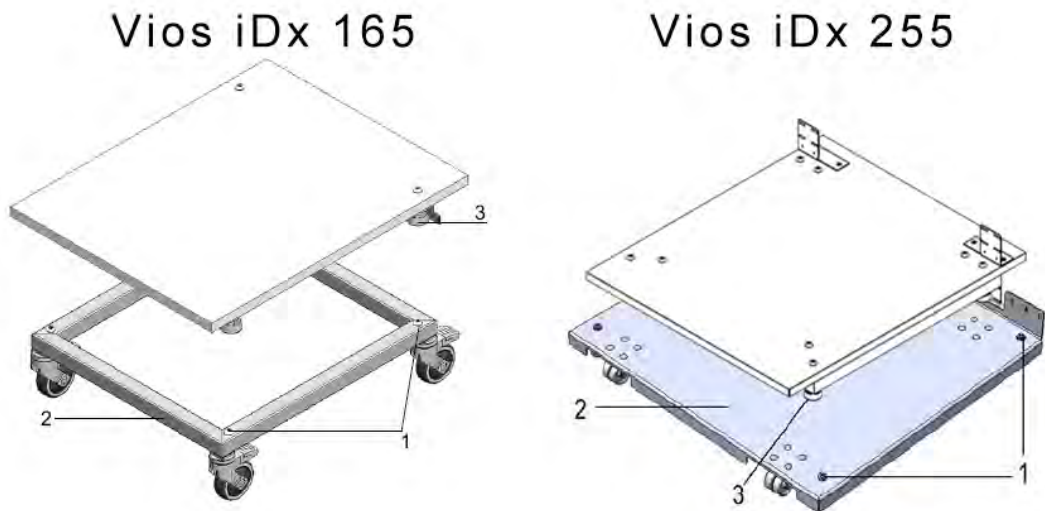

**Figure 2-4.** Stacking frame and base frame with stacking elements

2. Place the adapter plate (Figure 2-5, 7) with the underside on the top of the lower device (Figure 2-5, 8).
3. Align the holes in the connection tab (Figure 2-5, 9) of the adapter plate (Figure 2-5, 7) on both sides with the holes in the rear wall of the lower device (Figure 2-5, 8).

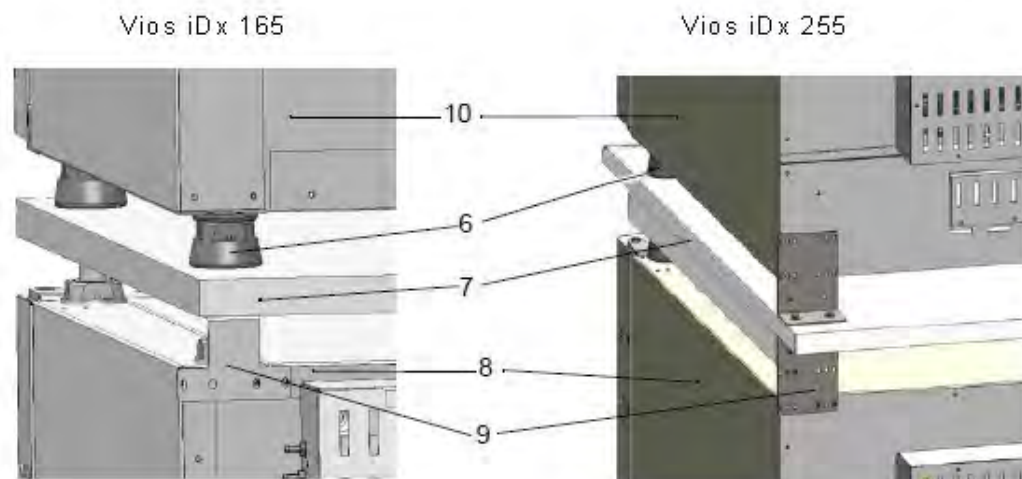
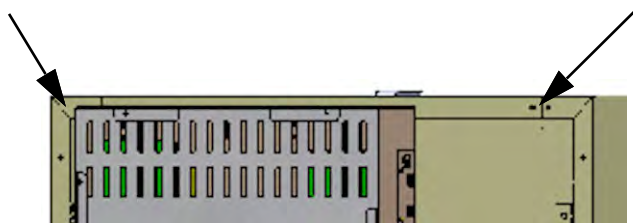

**Figure 2-5.** Screwing the adapter plate to the lower device

4. Screw the adapter plate (Figure 2-5, 7) to the rear wall of the lower device using the fastening screws provided (Figure 2-5, 8).
5. Attach the adapter plate (Figure 2-5, 7) to the other corner of the device using two screws.
6. Place the device to be stacked with the device feet (Figure 2-5, 6) on the stacking elements (Figure 2-4, 1) on the top of the adapter plate.

The devices are fixed to each other by the weight of the adapter plate (Figure 2-5, 7) and the upper device (Figure 2-5, 10).

7. Remove the four screws at the top rear edge of the top device; see arrows in Figure 2-6.



**Figure 2-6.** Removing the screws for the support frames

8. Bend both ends of the support frames (Figure 2-7, 4) by an angle of approximately 90° to obtain two right-angled tabs.
9. Use the four screws to secure the support frame to the back of the device, with the tab facing downward on the side of the device.
10. Make sure that the stacking feet of the upper device are correctly aligned on the stacking adapter.
11. Secure the support frames to a load-bearing structural part of the building using suitable mounting equipment, such as wood screws and dowels.

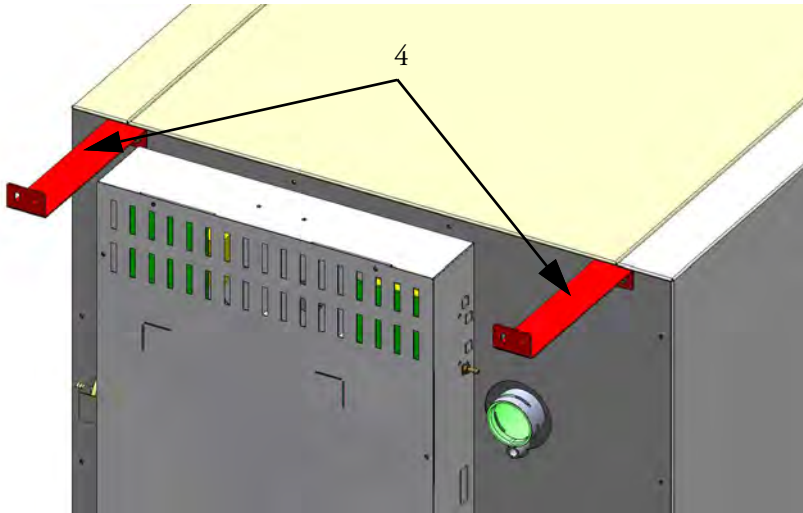

**Figure 2-7.** Mounting the support frames

## Stacking variants

Possible stacking combinations		Lower stacking position			
		Vios iDx 165	Vios iDx 255	150i	240i
Upper stacking position	Vios iDx 165	501712144	50171746	50148172	
	Vios iDx 255		50171746		50148175

For further information, refer to the stacking adapter kit assembly instructions.

## Installing casters on the base frame



### CAUTION

Ensuring stability

- Make sure that the base frame casters are locked during operation of the device and that the casters are facing forward.

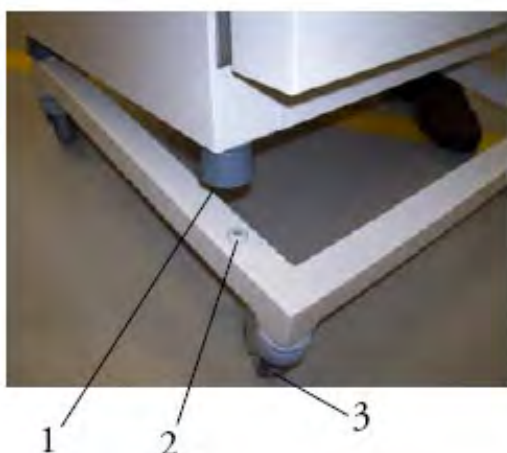

**Figure 2-8.** Base frame with casters, without feet (Vios iDx 165 version)

- Lock the base frame with the lever (Figure 2-8, 3) on the top of the casters.
- Place the feet of the device (Figure 2-8, 1) exactly on the 4 stacking plates (Figure 2-8, 2). To position the device, lift it only at the lifting points (Figure 2-2). Do not lift the device by the doors or components, such as the control box on the rear wall).

## Installing casters and feet on the base frame



### WARNING

The device must be moved with the greatest care. Careless braking or accelerating of the device may result in tilting from the base frame with casters. Do not move the device with the door open. The base frame with casters should only be used near the installation location in the laboratory and not for transportation purposes.



### WARNING

Ensuring stability

Ensure that the feet have been unscrewed and correctly adjusted after the device has been positioned in the desired location ("[Adjusting the feet](#)" on [Page 2-12](#)).



### WARNING

Heavy loads! Lifting hazard!

For the prevention of strain-related injuries, e.g. sprains and intervertebral disc lesions, never attempt to lift the incubator alone!

To avoid injury through falling loads, be sure to wear personal protective equipment, such as safety shoes, when lifting the incubator. To avoid crushing your fingers or hands (particularly when closing the door) or damaging the incubator, use only the lifting points indicated in the figure above.



### CAUTION

Please always screw in the feet of the assembled base frame completely before using it to move the incubator ("[Adjusting the feet](#)" on [Page 2-12](#)).



### CAUTION

Only lift the instrument by the lifting points shown in the figure ([Figure 2-2](#)).



**Figure 2-9.** Base frame with casters and feet

1. Remove the six screws at the bottom rear side of the device. They will be replaced with the six new screws.
2. Place the device on the base frame, ensuring that the feet are correctly positioned. Make sure that the holes of the removed screws exactly align with the holes in the corners of the base frame.
3. Insert the six new screws and tighten them.

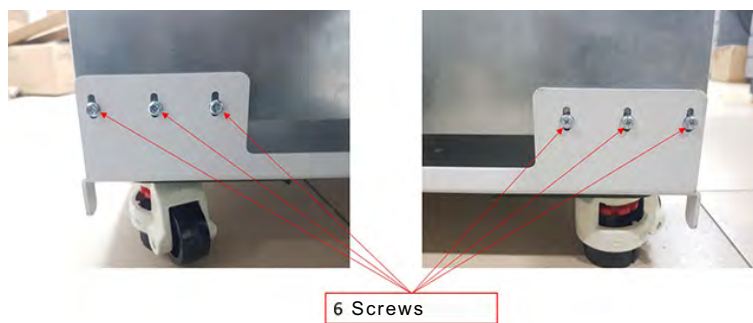



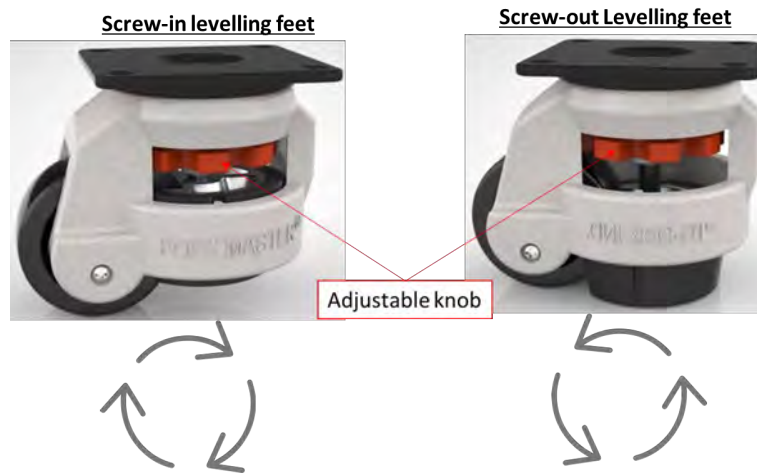

**Figure 2-10.** Screws on the rear of the device

4. Carefully push the base frame and the mounted device to the desired installation location.

- Adjust the base frame by screwing the feet onto the adjustment wheel until it is horizontal.



**Figure 2-11.** Adjusting the feet

Part number	Base frame options	Description
50170980		Base frame with casters for Vios iDx 165
50171152		Base frame with casters and feet for Vios iDx 165
50171157		Base frame with casters and feet for Vios iDx 255
50171568		Base frame for single chamber. Height: 780 mm (without casters) for Vios iDx 165
50171747		Base frame for single chamber. Height: 780 mm (without casters) for Vios iDx 255

# Retrofitting/modifications



## CAUTION

Modifications

Retrofitting and modifications may only be performed by the Technical Service of Thermo Electron LED GmbH.

The following components can be retrofitted to the standard version:

### Vios iDx 165

- Threefold segmented inner door (the segmented inner door is installed instead of the glass door)
- Door hinge replacement on outer door and glass door
- Sixfold segmented inner door with Cell Locker
- Lockable outer door
- IR180Si Infrared (IR) CO<sub>2</sub> sensor (replaces the standard TC180 WLD sensor)
- 4-20 mA measurement data interface

### Vios iDx 255

- Threefold segmented inner door (the segmented inner door is installed instead of the glass door)
- Door hinge replacement on outer door and glass door
- Lockable outer door
- Split insert shelves
- IR180Si Infrared (IR) CO<sub>2</sub> sensor (replaces the standard TC180 WLD sensor)
- 4-20 mA measurement data interface

## Description of the device

### Contents

- "Vios iDx 165/255 Front view" on Page 3-2
- "Vios iDx 165/255 Rear view" on Page 3-4
- "Safety devices Vios iDx 165/255" on Page 3-5
- "Workspace atmosphere" on Page 3-6
- "Door switch" on Page 3-10
- "Sensors" on Page 3-11
- "Supply interface" on Page 3-13
- "Workspace components" on Page 3-18
- "Heating system" on Page 3-22
- "Electromechanical door lock kit" on Page 3-24

## Vios iDx 165/255 Front view

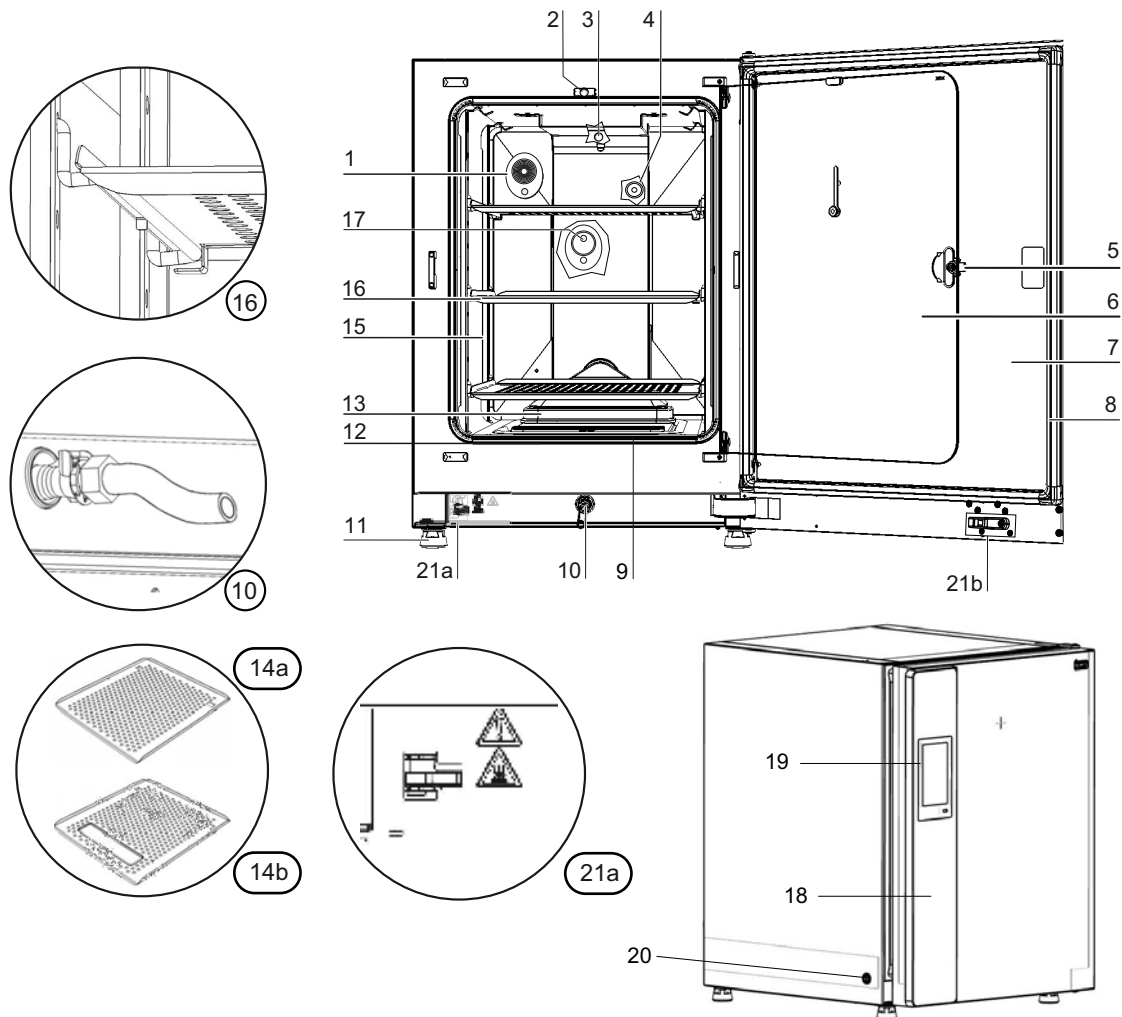

Figure 3-1. Vios iDx 165/255 Front view

Position	Unit
1	Pressure compensation opening/Access port with plug
2	Door switch for glass door
3	Temperature sensor
4	O <sub>2</sub> sensor (optional)
5	Handle of glass door or segmented inner door
6	Glass door or segmented inner door (optional)
7	Device door
8	Magnetic door seal, replaceable
9	Pre-filter
10	Water drain

Position	Unit
11	Foot, height-adjustable
12	Glass door seal, replaceable
13	Airbox with seal and HEPA filter
14	a/b shelves
15	Support rails
16	Shelf with support bracket
17	IR180Si CO <sub>2</sub> sensor
18	Door handle, outer door
19	iCAN2.0™ touchscreen (control panel)
20	Power switch
21	a = Electromechanical door lock / b - Closing hook on outer door (only on devices ordered with the optional door lock)

## Vios iDx 165/255 Rear view

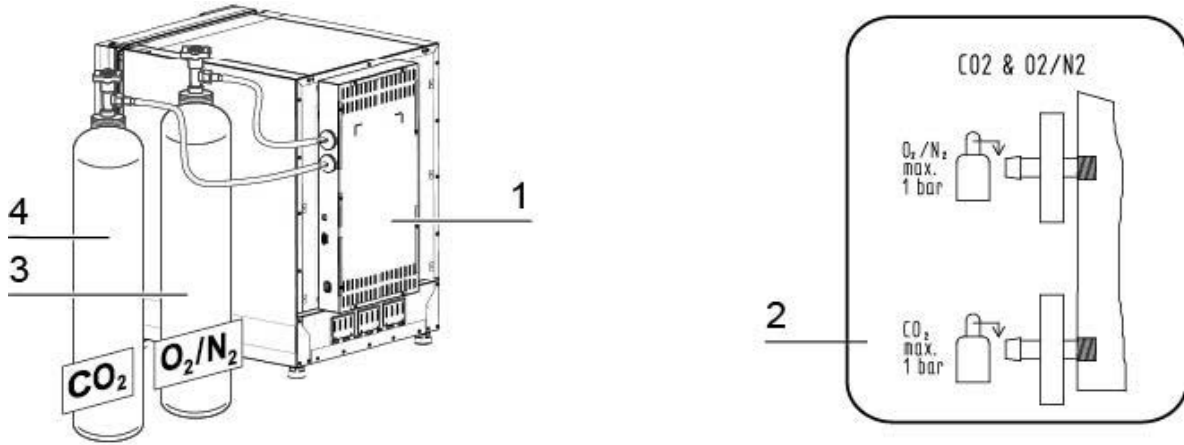

Figure 3-2. Vios iDx 165/255 Rear view

Position	Unit
1	Control box with supply interfaces for combined gas connection (optional) CO <sub>2</sub> and O <sub>2</sub> /N <sub>2</sub>
2	Diagram: CO <sub>2</sub> and O <sub>2</sub> /N <sub>2</sub> gas connection
3	O <sub>2</sub> /N <sub>2</sub> gas cylinder
4	CO <sub>2</sub> gas cylinder

## Safety devices Vios iDx 165/255

The device is equipped with the following safety devices:

- A door switch interrupts the heating of the workspace and the gas supply for CO<sub>2</sub>/O<sub>2</sub>/N<sub>2</sub> when the glass door is opened.
- An overtemperature protection protects the cultures from harmful overheating in the event of faults.
- A pressure compensation opening ensures pressure compensation in the workspace.
- The alarm relay circuit uses acoustic and visual alarms to indicate errors during operation.
- The active CO<sub>2</sub> control function <sup>1</sup>ensures optimal CO<sub>2</sub> gassing of your cultures by lowering excessively high values. For this purpose, the pump in the control box is activated, which sucks in ambient air via the air intake port and thus ensures that the CO<sub>2</sub> values (increase due to CO<sub>2</sub> emission by your cultures) do not exceed the respective selected set value. The CO<sub>2</sub> control function does not need to be separately activated; it is always active when the device is switched on.

---

<sup>1</sup> Optional..

## Workspace atmosphere

In the workspace of the incubator, the particular physiological ambient conditions for the preparation and cultivation of cell and tissue cultures are simulated. The workspace atmosphere is determined by the following factors:

- Temperature
- Relative humidity
- CO<sub>2</sub> concentration
- O<sub>2</sub> concentration (optional)

### Temperature

For trouble-free operation, the temperature of the operating room must be at least 18°C (64.4 °F), and the incubation temperature must be at least 3 °C (37.4 °F) above the room temperature of the operating room.

The heating system controls the incubation temperature from this temperature threshold up to 55°C (131 °F). By heating the inner compartment with independent heating circuits and by separately heating the outer door in addition, condensation is prevented on the sidewalls and the ceiling of the workspace and the glass door or segmented inner door.

### Relative humidity

The heating of the workspace promotes the condensation of the water, thereby ensuring a constant humidity within the workspace. For continuous operation, a sufficient quantity of processed water with the recommended water quality must be provided:

- Maximum filling quantity for Vios iDx 165/255: 3 L.

### Water quality recommendation

For trouble-free operation, the water reservoir must be filled with sterilized distilled water or water treated to an equivalent quality standard. The conductivity of the water should be within the range of 1 to 20 µS/cm (resistivity should be within the range of 50 kΩm to 1 MΩcm).

#### CAUTION

Termination of warranty!



Using chlorinated tap water or water additives that contain chlorine will void the manufacturer's warranty. The warranty is also voided if ultrapure water is used whose conductivity is outside the range of 1 to 20 µS/cm and whose resistivity is outside the range of 50 kΩcm to 1 MΩcm.

If you have any questions, please contact the Thermo Fisher Scientific Technical Service.

### CAUTION

No tap or ultrapure water in the humidity reservoir



Sterile distilled water or water treated to an equivalent quality standard is recommended for use in the integrated water reservoir. The acceptable conductivity should be within the range of 1 to 20  $\mu\text{S}/\text{cm}$  (resistivity should be within the range of 50  $\text{k}\Omega\text{cm}$  to 1  $\text{M}\Omega\text{cm}$ ). The pH should be in the range of 7-9. Type 1 ultrapure water or deionized (DI) water with a resistivity approaching or equal to 18.2  $\text{M}\Omega\text{cm}$  contains very few ions and will actively pull ions from interior components, damaging stainless steel, copper, and glass.

### CAUTION

Do not use chloride-containing disinfectants.



While stainless steel is resistant to corrosion, it is not corrosion-proof. Many chemicals have a negative effect on stainless steel, especially chlorine and derivatives with oxidizing activity.

The addition of chloride-containing disinfectants or copper sulfate to the water as a constant disinfectant is not recommended, as these can damage the connecting discharge joint, which is made of a steel/copper alloy. To clean the inside, a mild soap and water solution is recommended for rinsing out to remove residues. Wipe the interior surfaces and parts with a diluted quaternary ammonium disinfectant. Then wipe with 70% alcohol to remove any remaining traces of the disinfectant.

Under normal operating conditions and at the usual incubation temperature of 37°C (98.6 °F), a constant relative humidity of approximately 93% is achieved in the workspace. If condensation forms on the culture containers due to high relative humidity, the humidity in the workspace can be set at a lower level. With the activation of the low humidity mode, the relative humidity in the workspace falls from approx. 93% to approx. 90%. The change requires an extended adaptation phase. To ensure that it effectively prevents the formation of condensation on culture containers, it must be used as a permanent setting.

Instructions for activating the Low Humidity function are given in section „Adjusting humidity” on page 10.

## Pre-filter

A pre-filter is mounted on the front section of the water reservoir cover. The pre-filter consists of a dual-layer wire mesh with a silicone frame and is autoclavable as well as heat-resistant. The pre-filter must remain installed in the device during the Steri-Run sterilization cycle, but is removed for filling the water reservoir.

## HEPA filter and air duct

The air flow from the water reservoir to the workspace is channeled through a HEPA filter to minimize the risk of aerogenic contamination. The filter works with a capture rate of at least 99.95% @MPPS (HEPA filter quality). Smaller and larger particles are captured with even greater efficiency.

The HEPA filter (Figure 3-3, 2) is inserted into the airbox (Figure 3-3, 1) from below. The airbox sits on a base on the water reservoir cover (Figure 4-6, 2) and is pushed onto the fan inlet.

**Description of the device**  
Workspace atmosphere

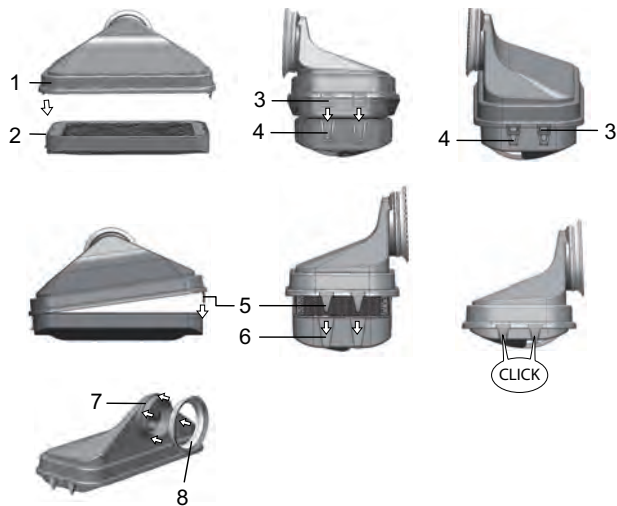

**Figure 3-3.** HEPA filter and airbox

Instructions for activating the HEPA filter can be found in section ["HEPA configuration"](#) on [Page 6-19](#).

The air duct channels the flow of air from the fan along the rear wall ([Figure 3-4, 3](#)) to the workspace ceiling, thus ensuring an optimum temperature distribution. At the same time, it directs the incoming stream of process gases into the workspace and ensures that the gases are optimally intermixed.

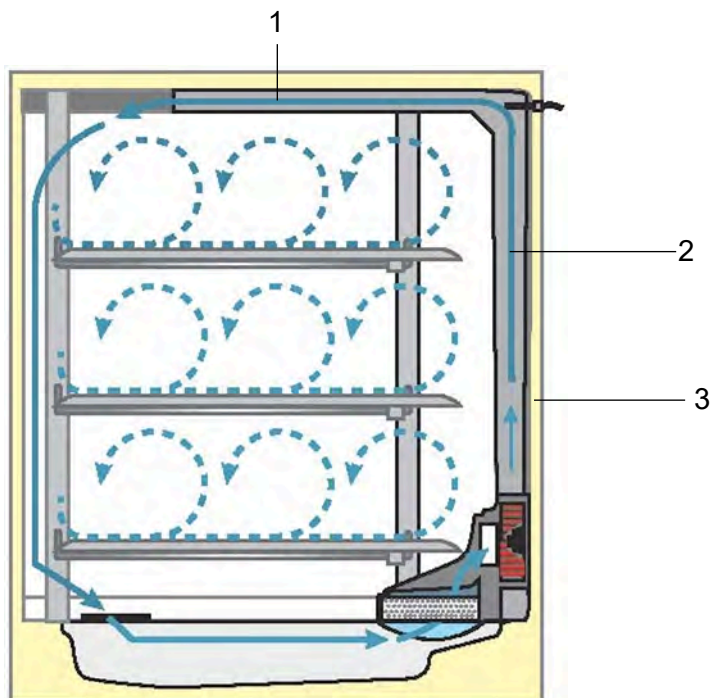

**Figure 3-4.** Air duct

The air duct consists of two fittings made of electropolished stainless steel or copper:

1. Ceiling duct ([Figure 3-4, 1](#))
2. Rear wall duct ([Figure 3-4, 2](#))
3. Rear wall of the workspace ([Figure 3-4, 3](#))

The air duct and HEPA filter can be installed and removed without any tools.

## Gas supply

### Note

Please note that the inner diameter of the gas pressure tube for Vios iDx 165/255 should be 3.175 mm.

### CO<sub>2</sub> supply

To ensure the growth conditions for the cell and tissue cultures, the workspace is supplied with CO<sub>2</sub>.

The pH of the bicarbonate-buffered culture media largely depends on the CO<sub>2</sub> level of the workspace atmosphere.

The CO<sub>2</sub> level of the workspace atmosphere can be controlled within a range of 0-20%.

The supplied CO<sub>2</sub> must have one of the following quality characteristics:

- Purity min. 99.5%
- Medical gas quality.

### O<sub>2</sub> supply

If the CO<sub>2</sub> incubator is to be operated with more than 21% oxygen, the workspace is supplied with oxygen (optional).

The O<sub>2</sub> level of the workspace atmosphere can be controlled within a range of 21% to 90%.

When operating at higher oxygen concentrations, the fire protection instructions in the "Preface" on [Page 0-1](#) and in the section "Safety notes on gases" on [Page 0-11](#) must be followed.

### N<sub>2</sub> supply

If the oxygen content during operation is to be lowered to below 21% (air oxygen content), the workspace is supplied with nitrogen. The O<sub>2</sub> level in the workspace atmosphere can be controlled in this way, depending on the version of the sensor.

## Door switch

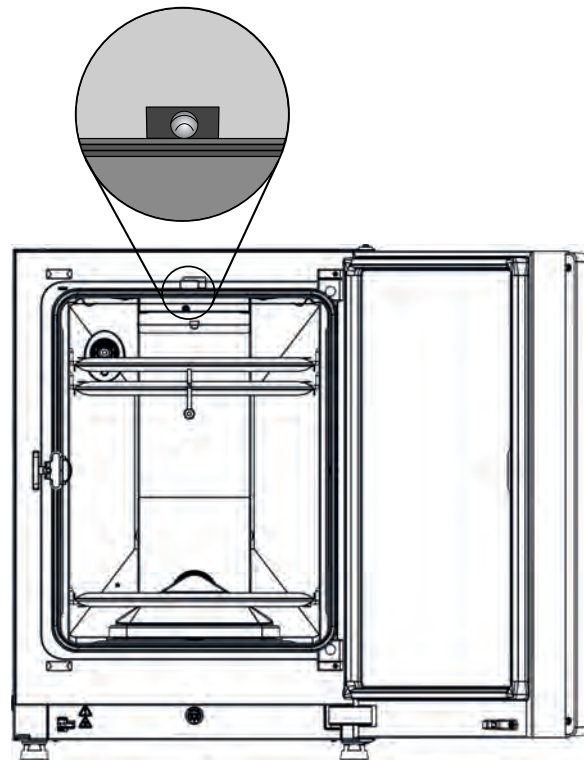

**Figure 3-5.** Door switch

A door switch is installed at the upper edge of the workspace opening. When the door switch is activated by opening the glass door, the gas supply and workspace heating are suspended. The display shows a corresponding message.

A short acoustic signal sounds if the door is open for longer than 30 s. If the door remains open for more than 10 min, a buzzer sounds and the alarm relay responds.

The outer door can only be closed after the glass door has been latched correctly.

### Note

Version with segmented inner door:

For devices with the optional segmented inner door, the door switch function described above is activated as soon as the outer door is opened.

## Sensors

The fan wheel and the sensor modules are installed in the rear wall of the workspace:

- Sensor for measuring the workspace temperature and the overtemperature protection (Figure 3-6, 1).
- O<sub>2</sub> sensor (optional) for measuring the oxygen level of the workspace atmosphere (Figure 3-6, 2).
- CO<sub>2</sub> sensor for measuring the CO<sub>2</sub> level of the workspace atmosphere (Figure 3-6, 3). Depending on the configuration, a TC180 WLD sensor or IR180Si IR sensor (option) is mounted in this location.
- RH sensor for monitoring the humidity of the workspace atmosphere (Figure 3-6, 4). The RH sensor (option) teams up with the TCD180 WLD sensor to provide humidity compensation and is not present on units operated with an IR180SI IR sensor.

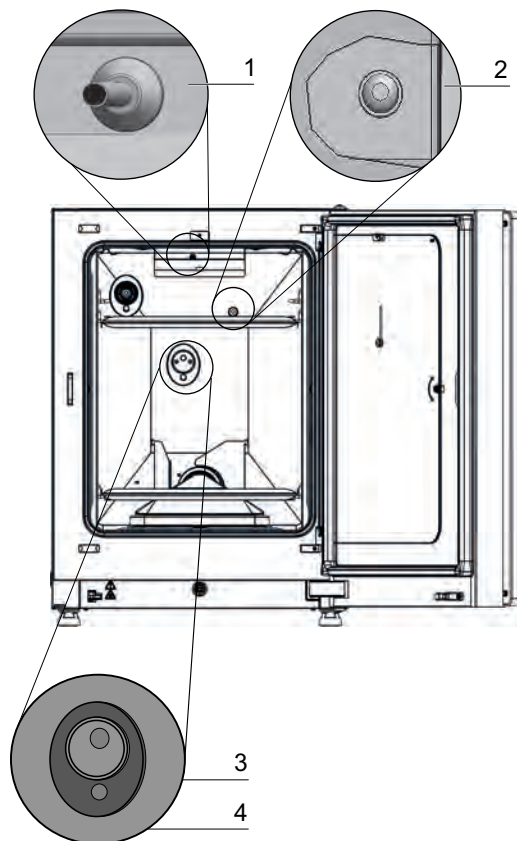
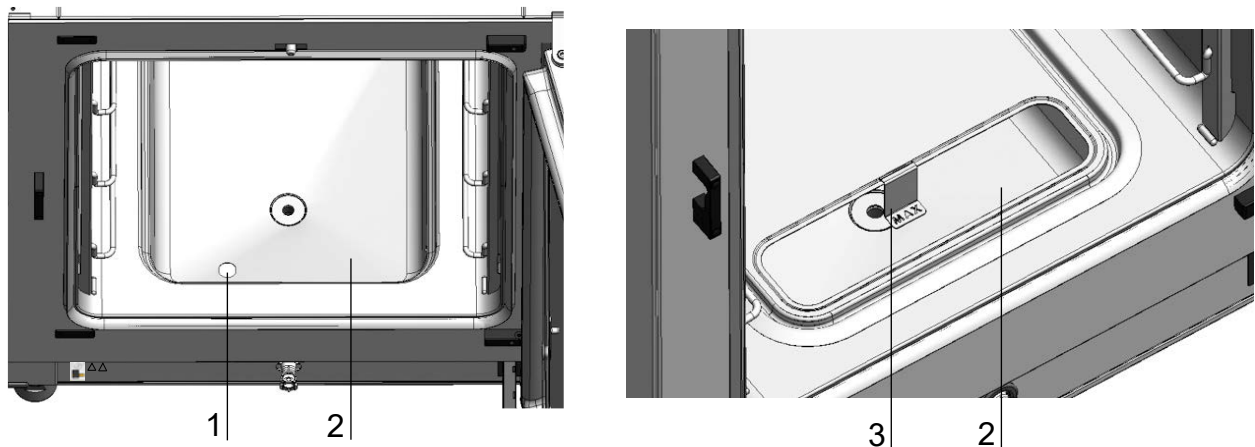

**Figure 3-6.** Temperature, O<sub>2</sub>, CO<sub>2</sub>, and humidity sensors

- The water level sensor (Figure 3-7, 1) alerts the user when the water reservoir (Figure 3-7, 2) needs to be refilled. If the water reservoir falls to 0.5 L, the message **Error - RH - No water** appears in the **RH** field of the display (see also "Error messages" on Page 6-46).

## Description of the device

### Sensors



**Figure 3-7.** Water level sensor

- Additionally, a mechanical/visual indicator of the maximum water level is available to assist the user in filling the water reservoir (see [Figure 3-7, 3](#)).

The sensor for measuring the workspace temperature as well as the CO<sub>2</sub> sensor and the optional O<sub>2</sub> sensor are part of the control system of the device. Their measured values are compared with the selected set values. Based on these data, the control system controls heating and CO<sub>2</sub>/O<sub>2</sub>/N<sub>2</sub> supply.

The fan ensures that the incoming gases are well intermixed with the humidified air, thus providing an even distribution of the atmosphere in the workspace.

The overtemperature protection feature is factory-preprogrammed and may only be changed by trained service personnel. It protects the stored cultures from overheating. If the set temperature is exceeded by more than 1°C (33.8 °F), the over-temperature protection is activated and the workspace temperature is automatically reduced to the selected set value. Incubation mode is thus continued even in the event of a fault. Any activation of the overtemperature protection simultaneously triggers a visual alarm. If the overtemperature protection is activated:

- an error message (Temp. actual value high) and a buzzer are issued,
- the alarm relay responds.

If the error message is acknowledged, the display shows the Overtemperature icon to indicate the response of the overtemperature protection, and the temperature display is highlighted in red.

# Supply interface

## Standard interfaces

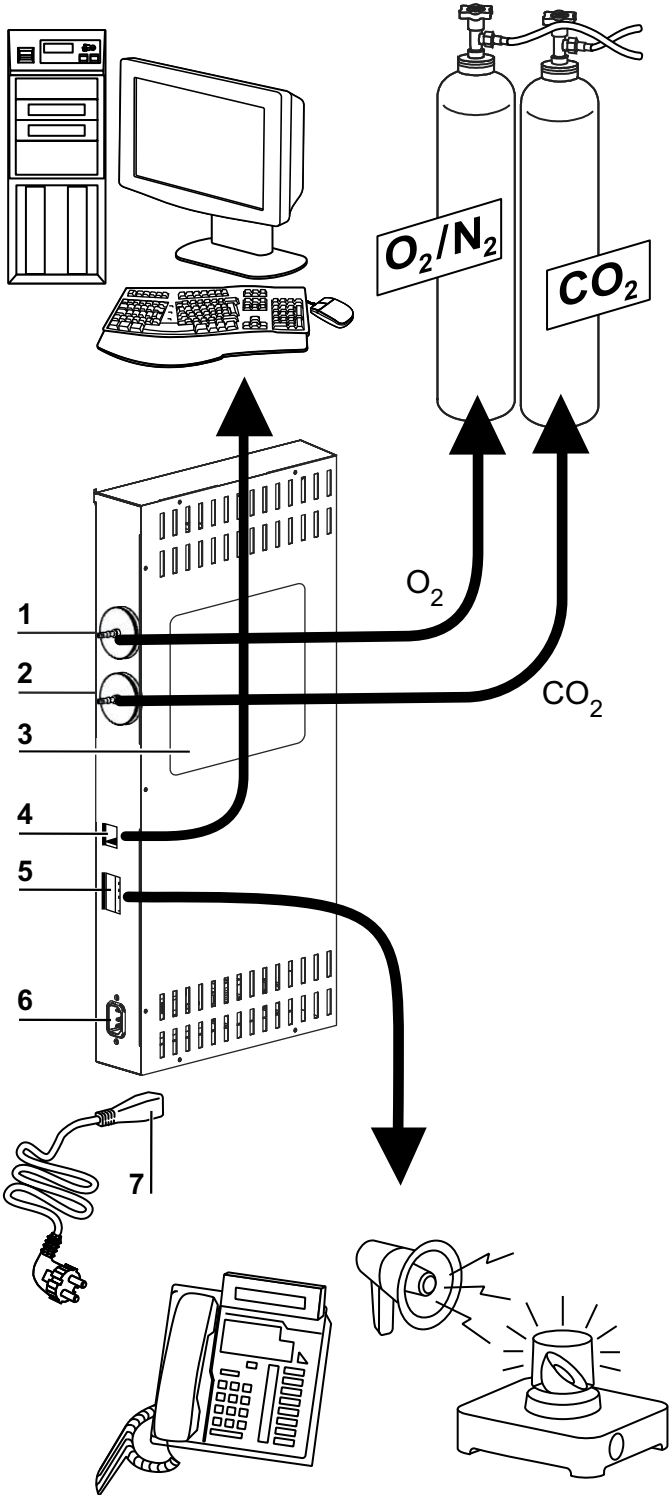

Figure 3-8. Device interfaces (right side of control box)

## Description of the device

### Supply interface

All supply connections are installed at the supply interface (control box) on the back of the device.

Mounted on the right side (Figure 3-8) of the control box are the connectors for the basic equipment as well as some optional elements:

1. O<sub>2</sub> connector
2. CO<sub>2</sub> connector
3. Label
4. USB interface
5. Alarm contact
6. Power connection
7. Mains plug

## Optional interfaces

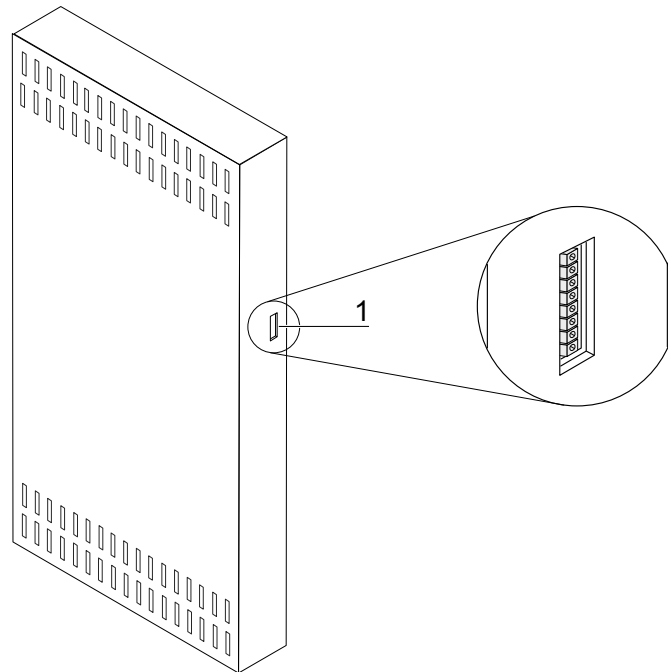

**Figure 3-9.** Optional device interfaces (left side of control box)

The connectors on the left side (Figure 3-9) are only available with devices equipped with the respective options:

1. 4...20 mA interface (optional)

## Gas connections

The gas supply lines between the device and the gas supply system are connected through the supplied connecting hoses. CO<sub>2</sub> and O<sub>2</sub>/N<sub>2</sub> are supplied to the device through connectors (Figure 3-8, 2, and 3, as well as Figure 3-9, 3). All process gasses must be supplied to the device at a fixed, pre-set, unchangeable pressure in the range of min. 0.8 and max. 1.0 bar. Before the gases are fed into the workspace, they flow through a gas inlet filter with a separation rate of 99.998% for a particle size of 0.3 µm. The figure shows the combined gas connection (optional).

## Label

The label (Figure 3-8, 4) contains information about gas supply, an alarm contact connection legend, and notes about the electrical fusing of the device.

## USB interface

The USB interface (Figure 3-8, 5) makes it possible to connect the incubator to a PC. This connection - USB 1.1 / USB 2.0 / USB 3.0 full speed compatible - allows fast (and temporary) access to the major operating parameters (temperature, CO<sub>2</sub>/O<sub>2</sub>/N<sub>2</sub> concentration, error codes, etc.).

## 4-20 mA Interface

The optional 4-20 mA interface (Figure 3-9, 2) converts the digital actual values displayed for temperature, CO<sub>2</sub> concentration, and O<sub>2</sub> concentration (optional) into a continuous output current of 4-20 mA each. This is accomplished by a microprocessor supported by a 4-channel D/A converter. The D/A converter provides a resolution of 16 bit per channel, equivalent to 65536 incremental values.

The interface port accepts various customer-supplied external measurement devices with 4-20 mA inputs, e.g. the Thermo Scientific Smart-View Wireless Monitoring System (not provided).

The table below lists the output signals:

Channel No.	Issued parameter (actual value)	Resolution	Measurement range	Output signal
1	Temperature	0.08 mA/°C 0.044 mA/°F	0...200 °C (32..392 °F)	4...20mA
2	CO <sub>2</sub> concentration	0.8 mA/%	0...20% CO <sub>2</sub>	4...20mA
3	O <sub>2</sub> concentration*	0.16 mA/%	0...100% O <sub>2</sub>	4...20mA
4	Free			

Parameters marked with an asterisk "\*" are only issued if the respective option is installed.

The measured values are governed by the following function:

$$DV = MR * (OS - I_0) / (I_{max} - I_0)$$

DV = displayed value (in °C or %)

MR = measurement range (in mA / °C or mA / %)

OS = output signal (in mA)

I<sub>0</sub> = 4 mA

I<sub>max</sub> = 20 mA

The meaning of the output signals is explained in the table below:

Current	Meaning
4 mA	The measured value is less than or equal to the minimum value of the measurement range.
20 mA	The measured value is greater than or equal to the maximum value of the measurement range.
2 mA	The device is fully functional, but there is no valid measured value available (e.g. the optional sensor is not installed, the device is in the heating phase, or similar).
0 mA	Error

The four 4-20 mA output signals are broken out onto a disconnectable, 8-pin terminal block (3,5 mm). The mating connector is delivered as a standard accessory. The pin assignment is shown in the following table.

Pin No.	Channel description
1	Channel 1: temperature
2	Channel 1 ground
3	Channel 2: CO <sub>2</sub>
4	Channel 2 ground
5	Channel 3: O <sub>2</sub>
6	Channel 3 ground
7	Channel 4: free
8	Channel 4 ground

## Alarm contact

### Note

Alarm contact:

The alarm contact responds to all errors reported by the control loops (see section Error messages).

The device can be connected to an external reporting system provided by the customer (e.g. telephone system, building management system, visual or acoustic alarms). For this purpose, a potential-free alarm contact is preinstalled in the device. This contact is led out of the control box on the back of the device (Figure 3-8, 6).

## Power connection

The device is connected to the power supply using a cable with an IEC connector plugged into the IEC socket in the control box (Figure 3-8, 7). The mains plug must be easily identifiable by the user and freely accessible at all times.

## Workspace components



### CAUTION

The HEPA filter cartridge is only resistant to temperatures up to 60°C (140 °F), is not autoclavable, and must be removed prior to the Steri-Run sterilization cycle.

## Inner chamber

The incubator workspace is designed in such a way that any contamination that could prove detrimental to incubation operation is excluded. This is achieved by preventing the formation of condensation and by using a HEPA filtration system built into the workspace, which protects the water supply used for humidification without compromising the area that can be used for incubating the cultures and ensures clean room air quality in accordance with ISO 5.

## Materials of the inner chamber

The standard version is equipped with an inner chamber made of electropolished stainless steel or 100% copper.

Depending on the material of the inner container, workspace components such as the air duct and shelving is also made of the same stainless steel or copper material.

The airbox for the HEPA filter is made of heat-resistant plastic material and must remain installed while the Steri-Run sterilization cycle is run.

### Note

Oxidation of copper components:

Exposure to heat and humidity leads to oxidation of the 100% copper material of the inner chamber. This results in discoloration of the copper components during the test run in the device check.

Do not remove the oxide layer when performing routine cleaning, as the anti-microbial effect of the copper material is intensified by the oxidized patina.

The shelving system components, the airbox, the air duct, and the water reservoir cover can be removed without any need for tools, leaving only the easily treated, surface-reduced inner chamber for cleaning and manual disinfection of the device.

## Glass door and optional segmented inner door

The standard version of the Vios iDx 165/255 devices are equipped with a single-locking door made of single-pane safety glass.

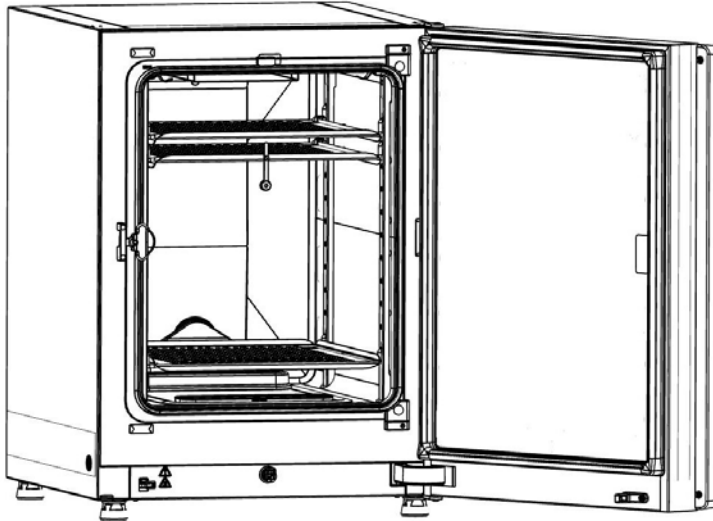

**Figure 3-10.** Vios iDx 165/255 with glass door

Devices equipped with the optional segmented inner door have a far lower risk of contamination due to the significantly smaller opening cross-sections when accessing the cultures and achieve shorter recovery times for the incubation parameters:

- Workspace temperature,
- CO<sub>2</sub> concentration
- O<sub>2</sub>/N<sub>2</sub> concentration,
- Relative humidity

The following segmented inner doors are available as optional equipment variants:

- Vios iDx 165: threefold segmented inner door (see [Figure 3-11](#)), Optional sixfold segmented inner door with Cell Locker (see [Appendix](#))
- Vios iDx 255: sixfold segmented inner door

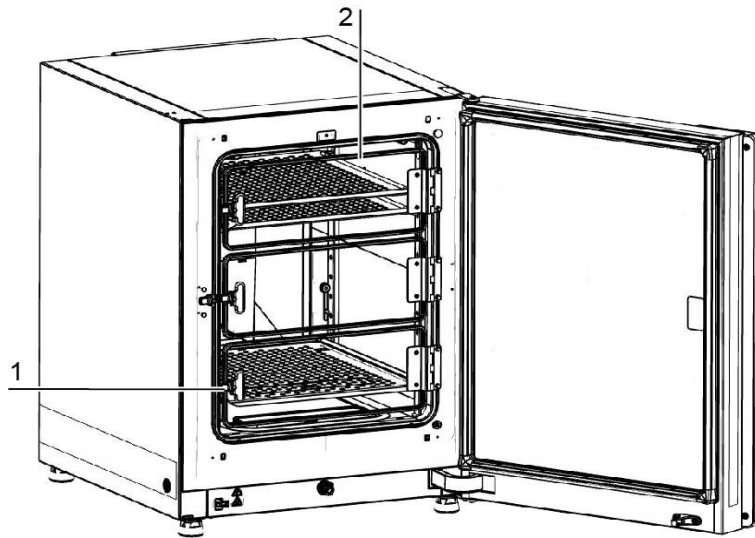

**Figure 3-11.** Vios iDx 165 with three-segment inner door

Each glass door of the segmented inner door (Figure 3-11, 2) possesses its own locking (Figure 3-11, 1).

## Water reservoir

The water reservoir is integrated into the floor of the inner chamber and is separated from the workspace by means of a cover. A drain (Figure 3-12, 2) provided in the front section of the water reservoir permits quick draining through the fill and drain valve (Figure 3-12, 3) located at the front section of the device.

In the front area of the water reservoir cover, a pre-filter (Figure 3-12, 4) is mounted. The pre-filter consists of a dual-layer wire mesh with a silicone frame and is autoclavable and heat-resistant. The pre-filter must remain installed in the device during the Steri-Run sterilization cycle, but is removed when filling the water reservoir.

Further information on filling with the sixfold segmented inner door can be found in the [Appendix](#).

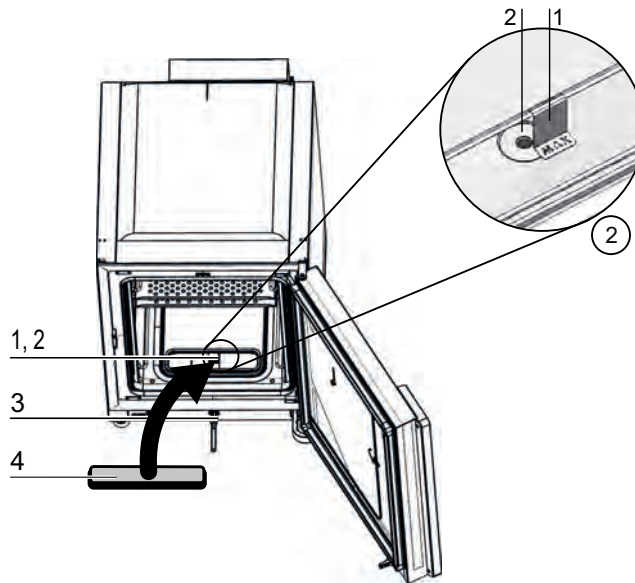
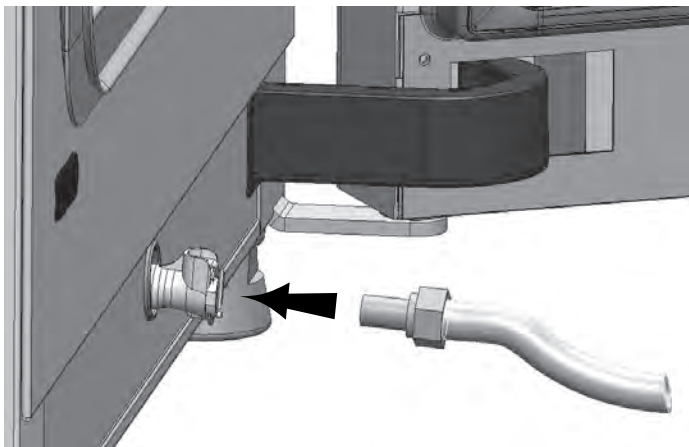

**Figure 3-12.** Water reservoir

The water reservoir is monitored by the water level sensor described in the section "[Sensors](#)" on [Page 3-11](#) .

A fill level indicator labeled "MAX" ([Figure 3-12](#), 1) is suspended in the water reservoir as a mark for the maximum fill level. The maximum permissible fill volume of the water reservoir is 3 L.

In order to minimize interference with the workspace atmosphere when water is changed during incubation, the device has a quick-drain valve at the front. Plugging the drain tube supplied into the quick-drain valve at the front starts draining immediately.



**Figure 3-13.** Fill and drain valve of the water reservoir

## Heating system

The workspace is heated by a surface heating system. The arrangement of the heating elements ensures that the formation of condensation above the water reservoir is largely prevented.

The outer door of the device and the perimeter of the door opening are also heated. The heat radiated onto the interior glass door prevents the formation of condensation.

The workspace of the device always remains visible, despite high humidity.

## Rear panel openings

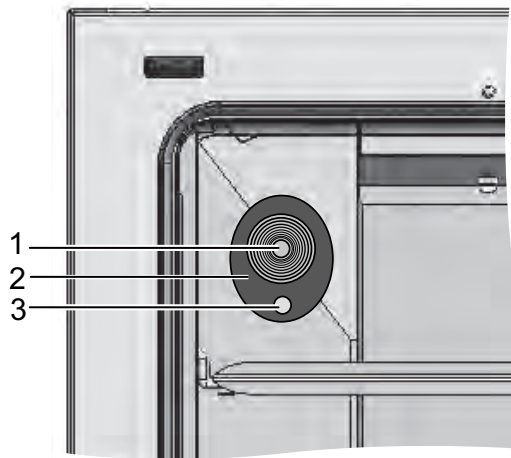

**Figure 3-14.** Rear panel openings

The pipe opening with insert (Figure 3-14, diameter 42 mm) which can be closed with a plug (Figure 3-14, 1) enables the installation of cables, hoses, or additional sensors in the device workspace.

The pressure compensation opening (Figure 3-14, 3) below the access port in the rear wall of the device ensures pressure compensation between the device workspace and the operating room.

**Note**

Operating conditions:

When accessories are used in the workspace of the CO<sub>2</sub> incubator, the ambient condition requirements must be observed (see table). The energy introduced into the workspace affects the beginning of the temperature control range. Introducing additional sources of heat into the workspace can lead to the formation of condensation (e.g. on the glass door).

Introduced energy	Beginning of the temperature control range	
	Generally	Example: RT* = 21°C (69.8 °F)
0 W	RT + 3°C (37.4 °F)	24°C (75.2 °F)
5 W	RT + 6.5°C (43.7 °F)	27.5°C (81.5 °F)
10 W	RT + 9.5°C (49.1 °F)	30.5°C (86.9 °F)
15 W	RT + 13°C (55.4 °F)	34°C (93.2 °F)
20 W	RT + 16°C (60.8 °F)	37°C (98.6 °F)

\*RT = Room temperature

## Shelf system

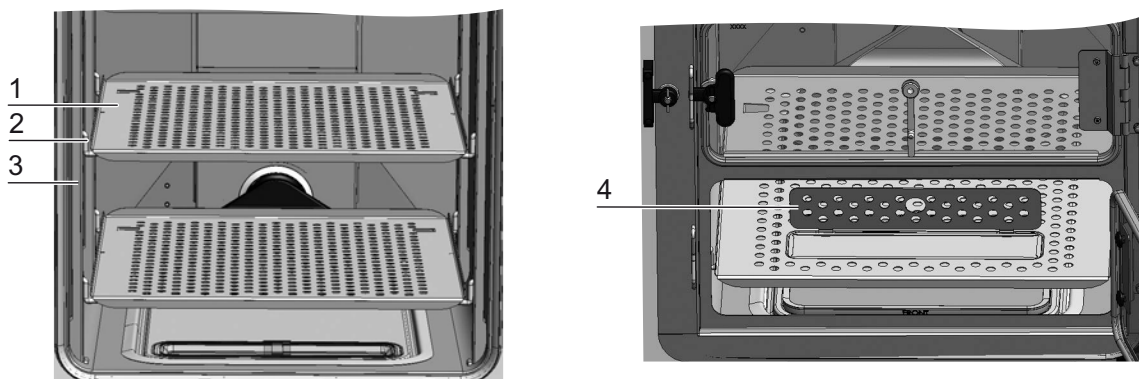

**Figure 3-15.** Shelf system components

The supporting rails (Figure 3-15, 3) of the shelving system must be perforated at intervals of 42 mm. The support brackets (Figure 3-15, 2) can thus be used variably for any required culture vessel size. A tilt protector and pull-out limiter are incorporated into the shelves ((Figure 3-15, 1). The Vios iDx 165/255 devices come with a lower shelf with a filling cut-out (Figure 3-15, 4). The shelving system is discussed in detail in the chapter "Start-up" on Page 4-1.

Further information on the use of the shelf system with a sixfold segmented inner door can be found in the [Appendix](#).

## Electromechanical door lock kit

The electromechanical door lock kit consists of a rotary latch (detail A in [Figure 3-16](#)) driven by a built-in motor, a built-in mechanical emergency release lever (detail C), and a locking hook (detail B) mounted on the inner side of the door.

The door lock kit is a safety device that prevents access to the incubator workspace during the Steri-Run sterilization cycle. This safety device locks the incubator door as soon as the workspace temperature reaches/exceeds 65°C (149 °F). On completion of the Steri-Run sterilization cycle, the door lock kit unlocks the door shortly after the temperature drops below 65°C (149 °F).

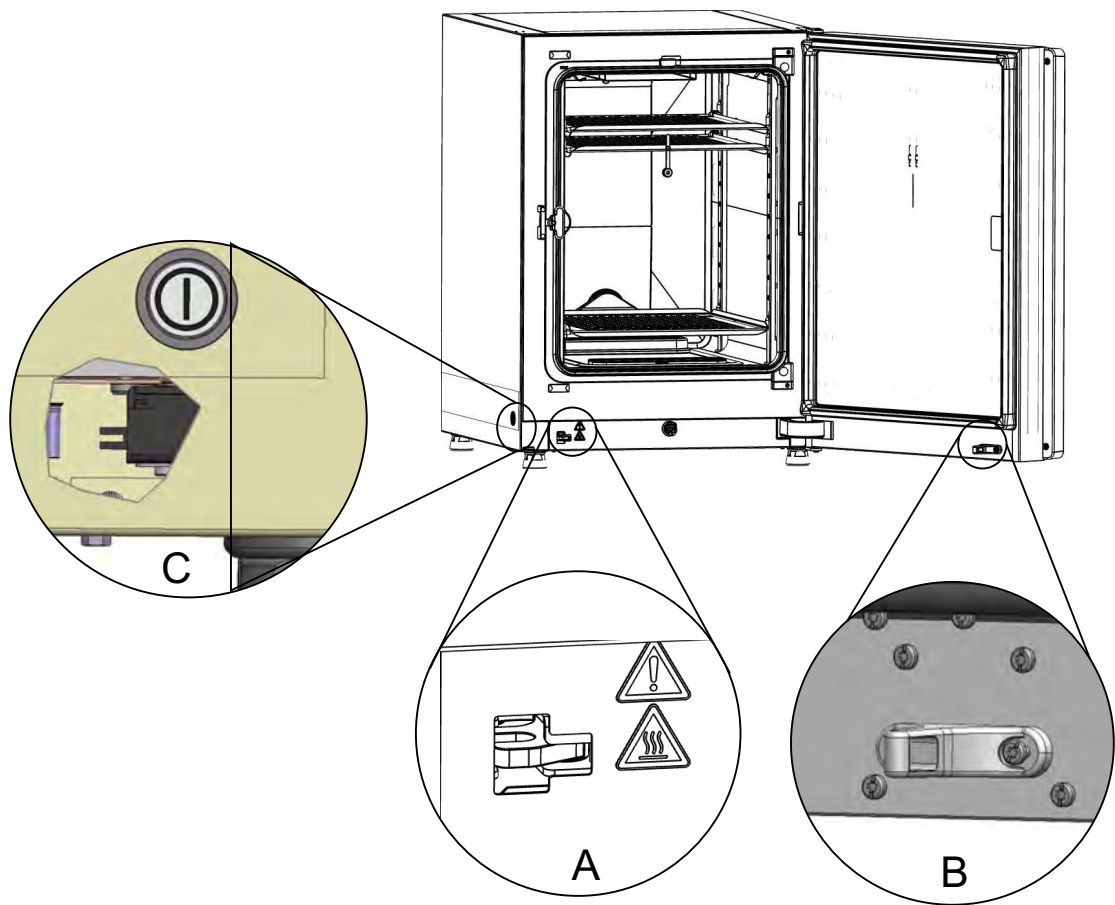

**Figure 3-16.** Door lock lever and emergency release

When a power failure occurs, the latch stays in its current position. When power returns, and the decontamination routine continues, the latch unlocks the door automatically when the temperature drops below 65°C (149 °F). If necessary, the door may be unlocked at any time by pulling the emergency release lever (C) towards the side wall. The emergency release lever is located on the underside of the incubator next to the power switch. Detail C in [Figure 3-16](#) shows a section view through the side wall to illustrate the position of the lever.

# Start-up

## Contents

- "Acclimatizing the device" on Page 4-2
- "Preparing the workspace" on Page 4-2
- "Installing the "MAX" fill level Indicator and the pre-filter" on Page 4-3
- "Air duct" on Page 4-4
- "Installing the shelf system" on Page 4-7
- "Vios iDx 255 split insert shelves (optional)" on Page 4-9
- "Connecting the gas" on Page 4-10
- "Power connection" on Page 4-13
- "Connecting the USB interface" on Page 4-14
- "Connecting the alarm contact" on Page 4-14

## Acclimatizing the device



### CAUTION

Acclimatize the device!

Prior to start-up, allow sufficient time for the device to acclimatize.

- Before switching on, stand the instrument for approximately 2 h in the operating room at the expected operating room temperature.
- Open the instrument doors.

## Preparing the workspace



### CAUTION

Observe the notes and technical data in the manuals delivered with replacement parts or accessories. The instructions or technical data may differ from those stated in this manual.

### Note

Disinfection:

Details of the cleaning and disinfection of the device are described in a separate chapter (see "[Cleaning and disinfection](#)" on [Page 8-1](#)).

Upon delivery the CO<sub>2</sub> incubator is not in a sterile state. Prior to starting operation, the device must be cleaned and disinfected.

In addition, the following workspace components must be previously cleaned and disinfected:

- Support rails
- Support bracket
- Pre-filter
- Air duct
- Airbox
- Insert shelves
- Workspace surfaces
- Glass door seal
- Glass door/segmented inner door

## Installing the “MAX” fill level Indicator and the pre-filter

The “MAX” fill level indicator and the pre-filter can be installed without tools:

1. Make sure that the tube is removed from the fill and drain valve (Figure 4-2, 3).
2. Check whether the drain (Figure 4-2, 2) in the front section of the water reservoir is free of obstruction; it is needed for discharging the water through the fill and drain valve (Figure 4-2, 3) on the front of the device.
3. Hang the “MAX” fill level indicator (Figure 4-1, 1) in the slot provided in the water reservoir cover (Figure 4-1, 5).

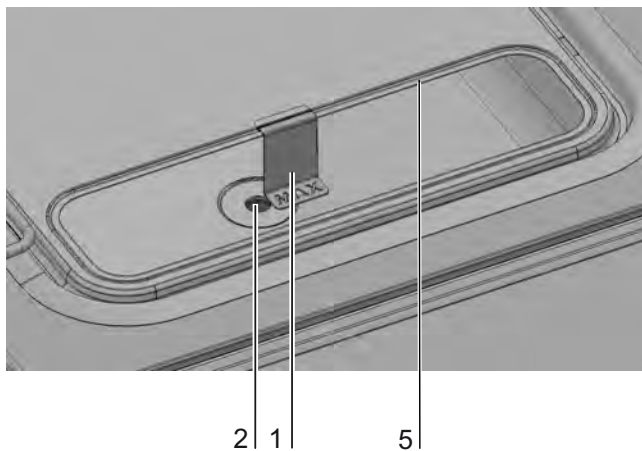

Figure 4-1. “MAX” fill level indicator

4. Insert the pre-filter (Figure 4-2, 4) into the water reservoir cover.

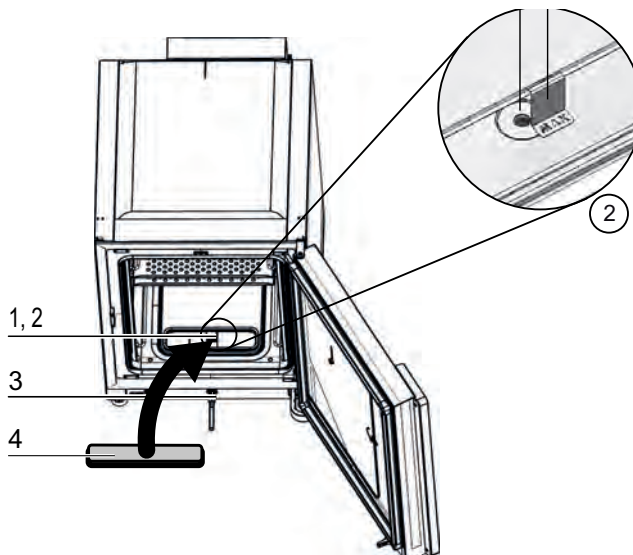

Figure 4-2. “MAX” Fill Level Indicator and pre-filter

# Air duct

## Components of the air duct

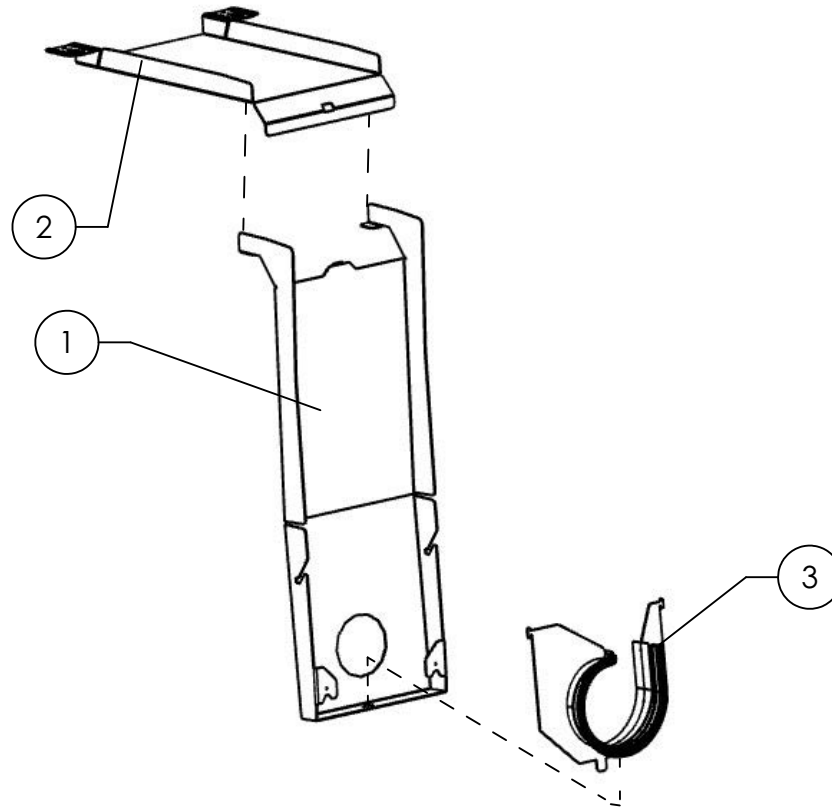

Figure 4-3. Air duct parts Vios iDx 165/255

Pos.	Name
1	LLB rear wall (replacement part includes 3 and 4)
2	LLB ceiling duct
3	Compressor plate with spiral seal profile

## Installation of the air duct

### Note

For Vios iDx 165 versions, do not remove the air duct seals before the rear wall is installed. The air ducts on the rear wall are important for correct airflow into the Vios iDx 165 versions with a stainless steel inner chamber.

1. Join the top part (Figure 4-4, 1) of the air duct to the back part (Figure 4-4, 2) according to Figure 4-4, steps A-E. When doing so, make sure that the positioning tab on the back part snaps into the corresponding square hole in the base part at step C in Figure 4-4.
2. Place the bar at the foot of the back part (Figure 4-4, 2) on the two stud bolts on the rear wall and tilt the air duct backwards.

3. Latch the keyholes at the sides on the upper part (Figure 4-4, G) in the retaining screws in the workspace ceiling.

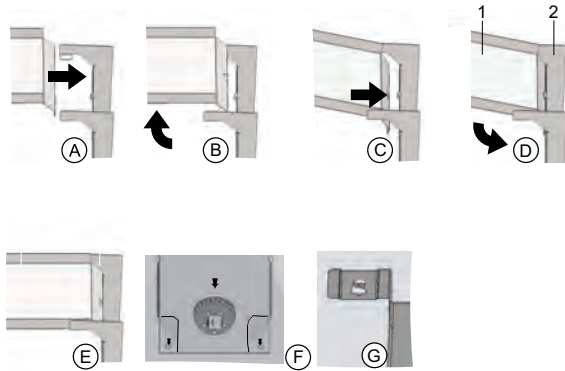

**Figure 4-4.** Assembling the air duct

## Installing the HEPA filter and water reservoir cover

The HEPA filter (Figure 4-5, 2) is inserted into the airbox (Figure 4-5, 1) from below. The airbox sits on a base on the water reservoir cover (Figure 4-6, 2) and is pushed onto the fan inlet.

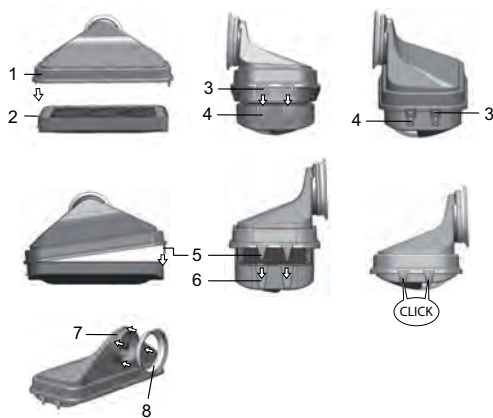

**Figure 4-5.** Assembling the HEPA filter and the airbox

1. Place the HEPA filter (Figure 4-5, 2) on a flat surface.
2. Tilt the airbox (Figure 4-5, 1) to the left and insert it with the tabs on the left side (Figure 4-5, 3) into the corresponding grooves in the HEPA filter (Figure 4-5, 4).
3. Snap the tabs (Figure 4-5, 5) on the right side of the airbox into the notches (Figure 4-5, 6)) of the HEPA filter.
4. Insert the seal (Figure 4-5, 8) into the groove (Figure 4-5, 7) on the pipe socket of the air box and press it tight all around.

## Start-up

Installing the HEPA filter and water reservoir cover

5. Mount the airbox (Figure 4-6, 1) onto the base (Figure 4-6, 2) of the water reservoir cover.

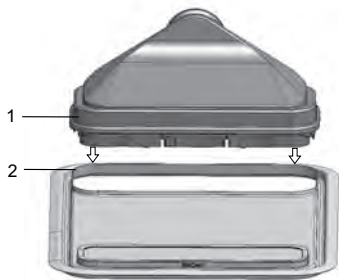

**Figure 4-6.** Mounting the airbox on the water reservoir cover

6. Place the water reservoir cover on the workspace floor.
7. Lift the water reservoir cover at the front and push it towards the rear wall (Figure 4-7, 1).

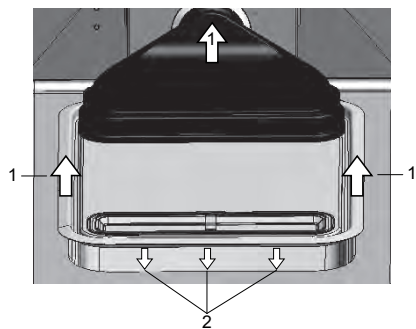

**Figure 4-7.** Installing the airbox

8. Push the water reservoir cover towards the rear wall until it stops. The cover slides into its final position in the reservoir, and the pipe socket of the airbox slides into the fan outlet.
9. Slide the leading edge of the water reservoir cover into the reservoir (Figure 4-7, 2). The airbox tubing slides into the fan outlet.

## Installing the shelf system

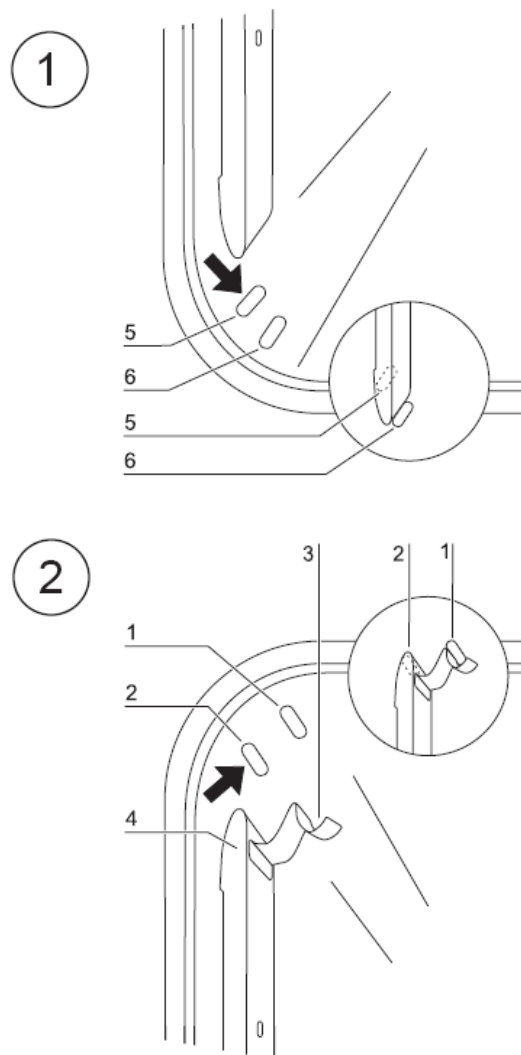

**Figure 4-8.** Shelf system installation/removal

Tools are not required for the installation of the shelf system. The support rails are secured using spring pressure.

### Installation/removal of the support rails

The support rails are guided and held in place at the sides by the recesses. The locking springs of the support rail must point upwards.

1. Place the support rail (Figure 4-8, 4) on the lower recess (Figure 4-8, 6) and fold it onto the side wall of the workspace so that the support rail sits above the two recesses.
2. Squeeze the retaining spring (Figure 4-8, 3) behind the upper recess (Figure 4-8, 1).
3. To remove the support rails, pull the locking spring (Figure 4-8, 3) on the tab downwards out of the recess (Figure 4-8, 1) and remove the support rail.

## Installing the support brackets

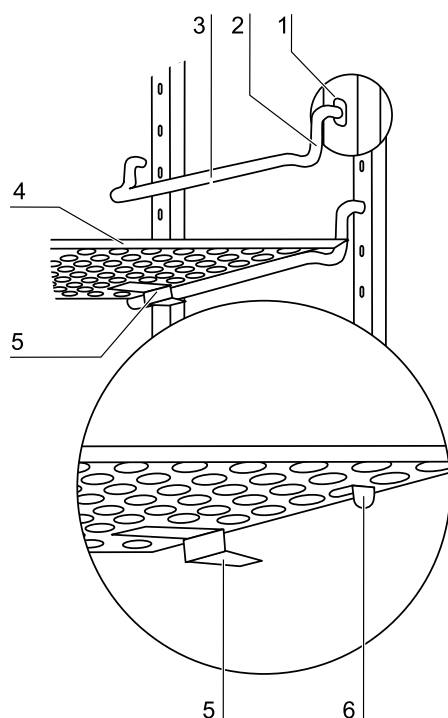

**Figure 4-9.** Installing the support brackets

1. Insert the support brackets (Figure 4-9, 3 + 2) into the perforation of the support rail (Figure 4-8, 1) so that the support rod (Figure 4-8, 3) points downwards.
2. Ensure that the two vertical pieces (Figure 4-8, 2) of the support bracket rest against the support rail.

### Installing the shelves:

1. Slide the insert shelves with the anti-tilt protection (Figure 4-9, 5) onto the support bracket, pointing towards the rear of the device. The anti-tilt protection is also used as a guide for the insert shelf.
2. Slightly raise the shelf so that the extension limiter (Figure 4-9, 6) can be guided over the support bracket.
3. Make sure that the support bracket runs freely in the two anti-tilt devices.

#### Note

Insert the shelf with the filling device (water) into the lowest position of the Vios iDx 165 incubator.

For the six-segment inner door, the support brackets are only inserted into the square holes; see [Appendix](#).

## Leveling the device



### CAUTION

Do not turn the feet out more than 13 mm.

1. Position a bubble level onto the center shelf or onto the roller holder.
2. Use a wrench (size 36 cm) to turn the device feet until the shelf is level and perpendicular in all directions. Perform the height adjustment of the device feet from left to right and from rear to front.

## Vios iDx 255 split insert shelves (optional)

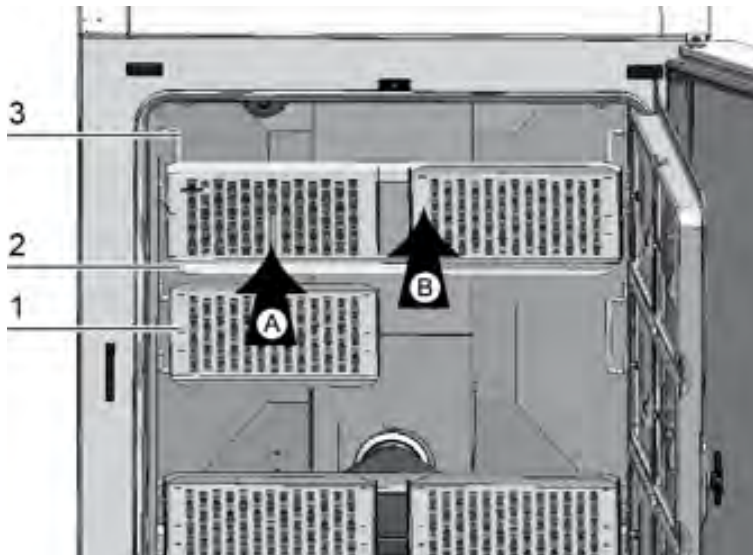

**Figure 4-10.** Installation of split shelves

If Vios iDx 255 with the optional sixfold segmented inner door and the shelves split into six are fitted, three support frames with two shelves each are placed on the support brackets of the side support rails instead of the one-piece shelves of the standard equipment.

1. Insert both shelves (Figure 4-10, 1) on the support frame (Figure 4-10, 2) (Step A)
2. Attach the supporting frames (Figure 4-10, 2) to the support bracket (Figure 4-10, 3) (Step B).

## Connecting the gas

### Note

Gas quality:

The gases must have one of the following quality characteristics:

- Purity min. 99.5%
- Medical gas quality.

### CAUTION

Overpressure!



The operating pressure of the gas supplied to the device must not exceed 1 bar. If the gas is supplied at a higher pressure, the valves integral to the device may not close correctly and the gas supply control may be impaired.

Adjust the gas supply to a range of min. 0.8 bar and max. 1 bar and make sure that this preset pressure cannot be changed!

## Installing gas pressure hoses

### CAUTION

Pressure compensation opening

To ensure permanent pressure compensation, the pressure compensation opening must not be connected to an exhaust air system. The pipe of the pressure compensation opening must not be extended or redirected.

### Note

Please note that the inner diameter of the gas pressure hose for Vios iDx 165/255 should be 3.175 mm.

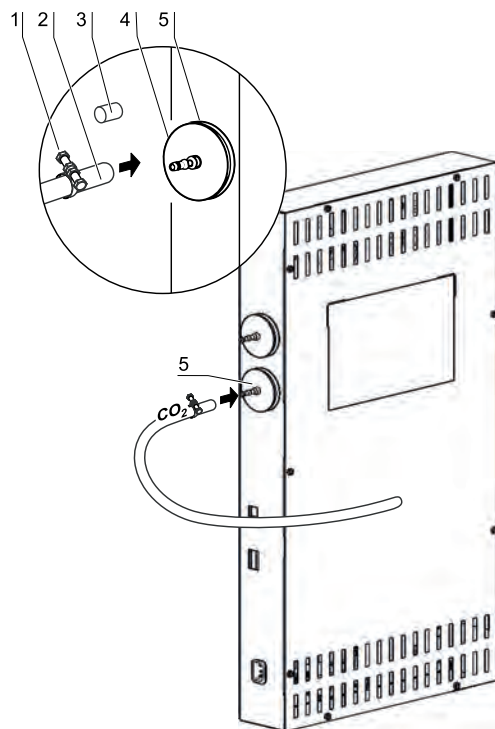
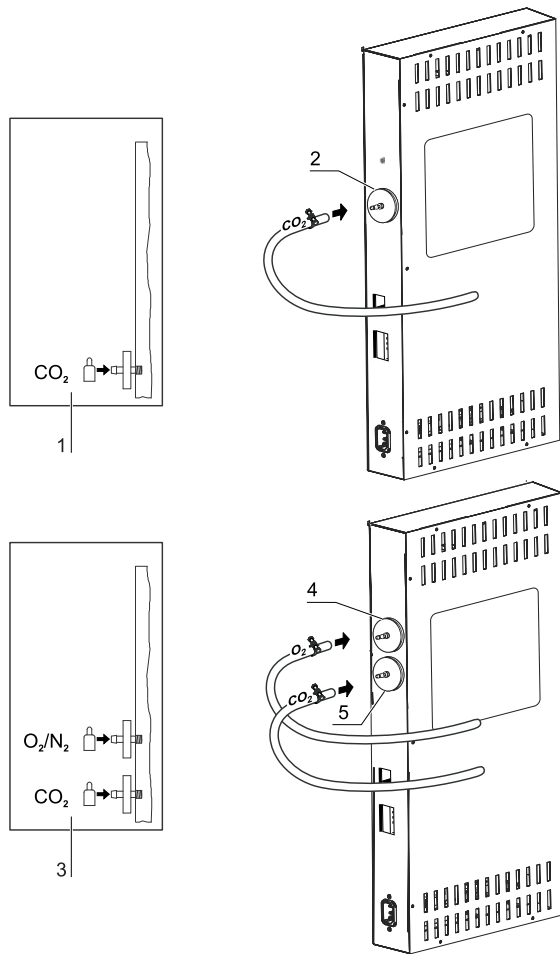

**Figure 4-11.** Installing gas pressure hoses

The supply of gas from the gas supply system to the device is established using the supplied flexible gas pressure hoses:

1. Attach the gas pressure hose to the connection port on the gas supply system.
2. Remove the protective cap (Figure 4-11, 3) of the gas intake filter.
3. Slide the hose clamp (Figure 4-11, 1) onto the gas pressure hose (Figure 4-11, 2) and connect the gas pressure hose to the connector (Figure 4-11, 4) of the gas intake filter (Figure 4-11, 5).
4. Fix the gas pressure hose to the connector of the gas intake filter using the hose clamp.

## Gas connection



**Figure 4-12.** Gas connection

The gas supply from the gas supply system to the device is established using the supplied flexible gas pressure hoses:

### CO<sub>2</sub> connection

- For a device with CO<sub>2</sub> connection, the gas supply is connected to the gas intake filter (Figure 4-12, 2) in accordance with the connection diagram (Figure 4-12, 1).

### Combined CO<sub>2</sub> and O<sub>2</sub>/N<sub>2</sub> connection (optional):

On devices with a combined CO<sub>2</sub>-/O<sub>2</sub>-/N<sub>2</sub> connection, the gas supply tubes must be routed according to the connection diagram (Figure 4-12, 3) as follows:

- Connect the O<sub>2</sub>/N<sub>2</sub> supply to the upper gas intake filter (Figure 4-12, 4),
- Connect the CO<sub>2</sub> supply to the lower gas intake filter (Figure 4-12, 5).

#### Note

Manual gas monitoring

The filling level of the gas cylinders must be checked every day.

## Power connection

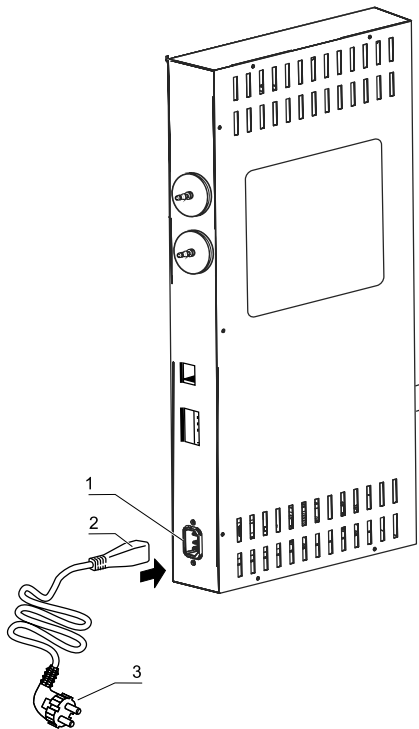

Figure 4-13. Power connection

### DANGER

Electric shock!



Contact with current-carrying components may cause a lethal electric shock. Before connecting the device to the power supply, check plug and power cable for damage. Do not use damaged connection components to connect the device to the power supply!

- Connect the unit to a correctly installed and grounded mains supply fused with a B 16 circuit breaker.

## Connecting to the power supply

### DANGER



The mains plug must be easily identifiable by the user and freely accessible at all times. The power cord plug is the all-pole disconnecting device from the mains supply.

### DANGER



To ensure safe operation of the device, use the original power cord. For questions and requirements, please contact your Thermo Fisher service organization!

1. Before connecting the device to the power supply, check to see if the voltage of the power outlet corresponds to the specifications on the nameplate to the left of the device power

## Start-up

### Connecting the USB interface

switch. If the ratings given for voltage (V) and current (A) do not correspond, the device must not be connected.

2. Insert the IEC connector into the socket on the control box of the device.
3. Insert the grounding plug of the power cable into a properly grounded and fused outlet.
4. Make sure the power cable is not subjected to tensile or compressive force.

## Connecting the USB interface

The devices come equipped with a USB interface as a standard feature. The connection to the PC is made using a commercially available USB 1 or USB 2 cable (incubator side: USB connector type B, PC side: USB connector type A).

The USB interface complies with USB 1.1 standard and is compatible with USB 2.0 and 3.0 (full speed) standards. Data communication between the PC and incubator across the USB interface requires that a suitable driver be installed on the PC, unless such software is provided by the currently installed Windows version. The installation of the driver is described in "[Data communication](#)" on [Page 12-1](#).

## Connecting the alarm contact

### Note

Technical work

Thermo Scientific warrants the safety and functionality of the device only if installation and maintenance are performed properly.

The connection of the device to an external alarm system may only be carried out by trained and authorized electrical/telecommunications engineers!

Function:

When system errors and failures occur in the temperature or gas control loops, an alarm message is issued to the connected alarm/monitoring system. The potential-free contact (1 changeover contact) is designed for the following circuits:

## Alarm relay

### Note

Circuit structure

The alarm relay responds to all errors reported by the control loops (see "[Error messages](#)" on [Page 6-46](#)).

<b>Circuit</b>	<b>Voltage</b>	<b>External fusing</b>
Circuits with AC mains voltage	max. 250 V ~	max. 6 A
SELV circuits (cf. VDE 0100, part 410)	25 V ~	max. 2 A
	60 V =	max. 1 A
SELV E circuits (cf. VDE 0100, part 410)	50 V ~	max. 1 A
	120 V =	max. 0.5 A

  

<b>Operating states</b>	<b>Contact 3 - 2</b>	<b>Contact 3 - 1</b>
Operational Power monitoring "OFF"	X	O
Operational Power monitoring "ON"	O	X
Error Power monitoring "OFF"	O	X
Error Power monitoring "ON"	X	O

Legend: X: contact closed / O: contact open

**Start-up**  
Connecting the alarm contact

**Connection example:**

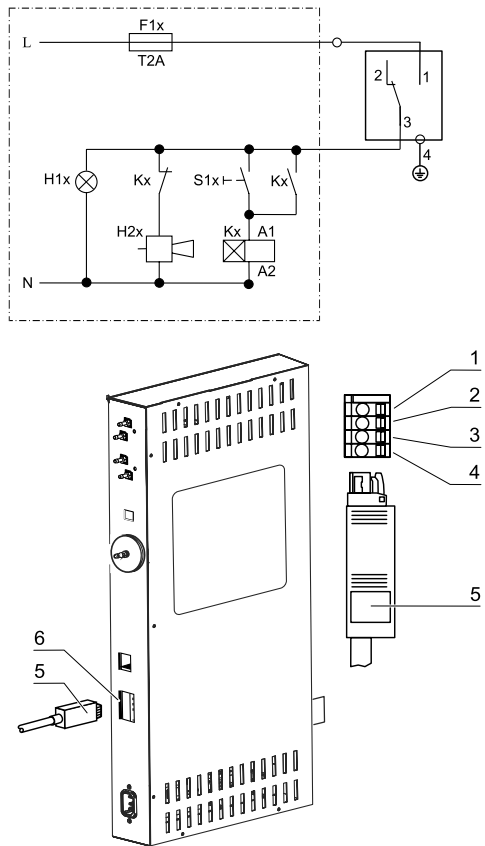

**Figure 4-14.** Example of alarm contact connection

**Note**

The plug (Figure 4-14, 5) for connecting the connection cable is not included in the scope of delivery but can be ordered separately. The values for the operating voltage and the fusing of external alarm circuits are given in the table above.

1. Clip on the individual strands of the connection cable (Figure 4-14, 1-4) according to the assignments in the power connection diagram (Figure 4-14).
2. Insert the plug of the connection cable (Figure 4-14, 5) to the external alarm system into the interface (Figure 4-14, 6) on the control box on the back of the device.

## Connecting the 4-20 mA interface

### Note

Technical work

Thermo Scientific warrants the safety and functionality of the device only if installation and maintenance are performed properly.

The connection of the device to an external alarm system may only be carried out by trained and authorized electrical/telecommunications engineers!

### Note

Retrofitting of the 4-20 mA measurement data interface is exclusively reserved for Thermo Fisher Scientific Technical Service staff.

The following figure shows the pin-out of the 4-20mA measurement data interface:

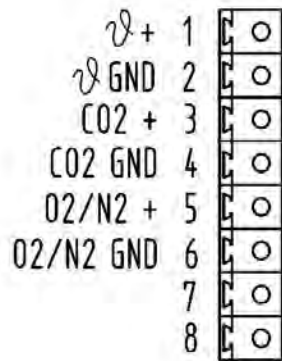

4...20mA

**Figure 4-15.** Pin-out of the 4-20 mA interface

# Operation

## Contents

- "Preparing the device" on [Page 5-1](#)
- "Starting operation" on [Page 5-3](#)

## Preparing the device



### CAUTION

The device may only be released for operation when all major start-up steps have been performed (see "[Start-up](#)" on [Page 4-1](#)).

## Device check

Prior to starting operation, the condition of the following components must be checked in a device check:

- Gas hoses must be seated tight on the connecting filters and must be secured using a hose clamp.
- The access port must be closed.
- The pressure compensation opening must be permeable; its insert must be installed in the workspace.
- The glass door seal must not be damaged.
- The measurement opening of the glass door/segmented inner door must be closed.
- The shelf system components must be installed safely.
- The airbox with the HEPA filter and the air duct must be properly installed.

## Decontaminating the device workspace



### CAUTION

Operating temperature limits for the Cell Locker!

- Remove the Cell Lockers prior to performing a Steri-Run sterilization cycle.

The maximum operating temperature for Cell Lockers is 121°C/250°F.

Cell Lockers melt in the incubator if exposed to the Steri-Run cycle.

Cell Lockers can be sterilized in an autoclave at 121°C (250 °F) for 15 minutes with rapid depressurization.

Cell Locker membrane filters may not be sterilized in an autoclave.

### Note

Hygiene guidelines:

To protect the cultures, the device workspace must be cleaned and disinfected before any operation in accordance with the hygiene guidelines to be established by the operator.

Water store: see "[Relative humidity](#)" on [Page 3-6](#).

If the minimum fill quantity is not reached, the water must be topped up, otherwise the alarm will be triggered.

- Perform the Steri-Run sterilization cycle (see "[Steri-Run sterilization cycle](#)" on [Page 8-5](#)) or disinfect the workspace according to the hygiene guidelines established by the operator.

Fill quantity Vios iDx 165: 3 L

Fill quantity Vios iDx 255: 3 L

## Starting operation

### Note

During cell cultivation in the culture chamber of the incubator, your cell cultures may themselves emit CO<sub>2</sub> after a certain period of time, and the CO<sub>2</sub> supply limits may be exceeded (depending on the selected set value). To prevent this, you can use the optional CO<sub>2</sub> control function, which is always active and automatically activates the air intake pump if the limits are exceeded.

The starting of the pump and the associated noises are not a malfunction and are completely normal in this case. As soon as the actual CO<sub>2</sub> value in the culture chamber is reached again, the pump will stop working and the noise level will return to normal.

Occasionally, if the set values are very high (max. 20%), the pump (if the CO<sub>2</sub> control function is selected) may start without a reason. This is also harmless; the pump will then stop on its own after 1-2 minutes.

1. Open the glass door or the segmented inner door.
2. Remove the pre-filter ([Figure 5-1](#), 2).
3. Open the insert shelf with filling cut-out (Vios iDx 165): Open the flap ([Figure 5-1](#), 3). One-piece insert (Vios iDx 255): Remove the lower insert shelf if there is not enough space for the container used for filling, or use a funnel and tube that have been sterilized in an autoclave or treated with 70% ethanol.
4. Pour sterilized distilled water into the base pan (under cover position 1 in [Figure 5-1](#)) of the workspace.

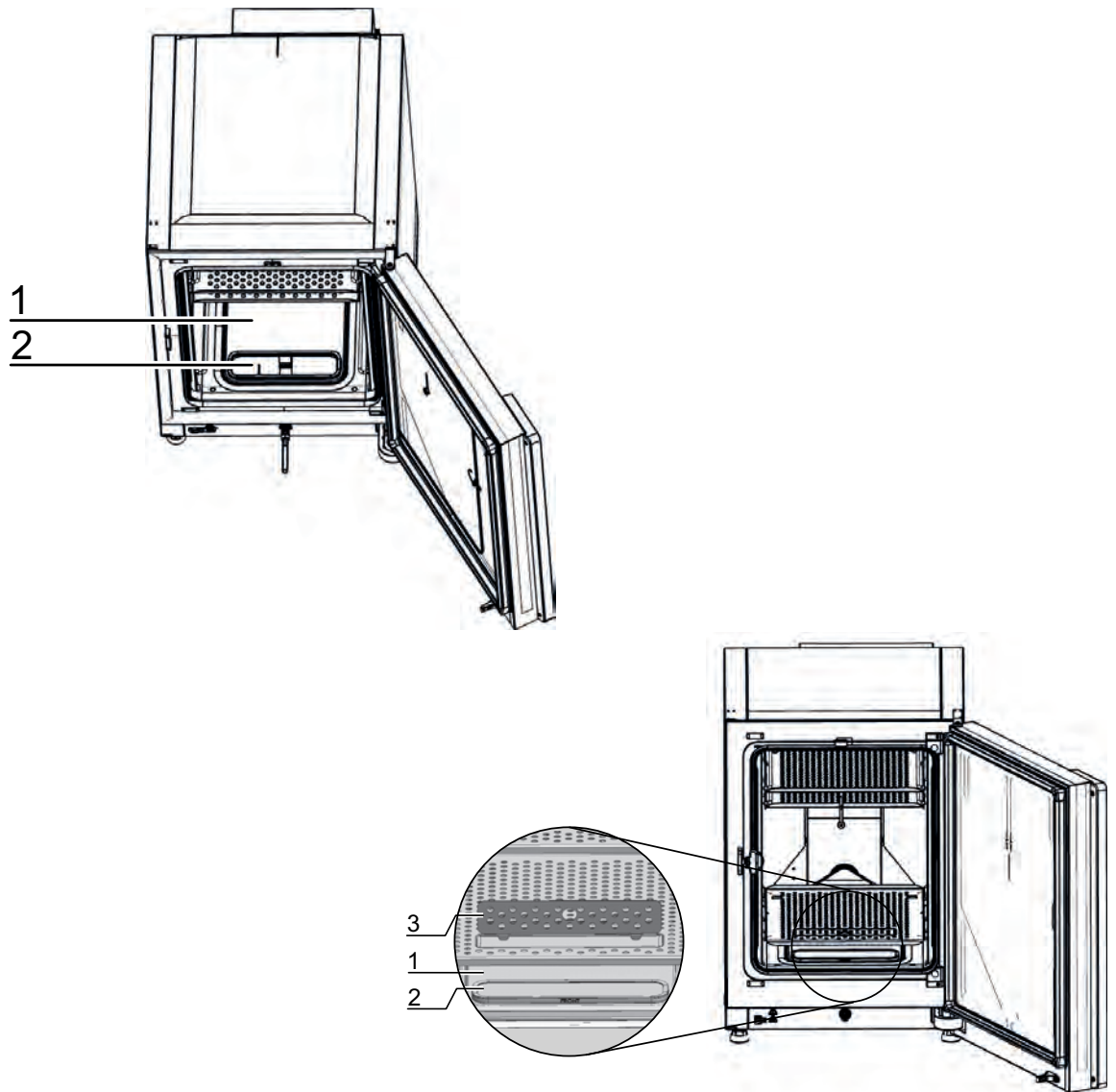
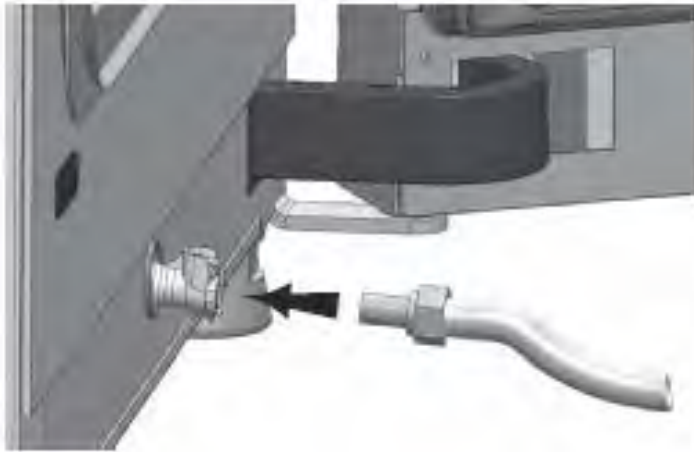

Figure 5-1. Water reservoir

**Note**

Do not exceed the maximum fill mark "MAX" (Figure 5-3, 1). The maximum fill volume of the water reservoir (Figure 5-3, 5) is 3 L.



**Figure 5-2.** Incubator fill and drain valve

5. Connect the tube to the fill and drain valve.
6. Add water until the maximum level mark is reached.

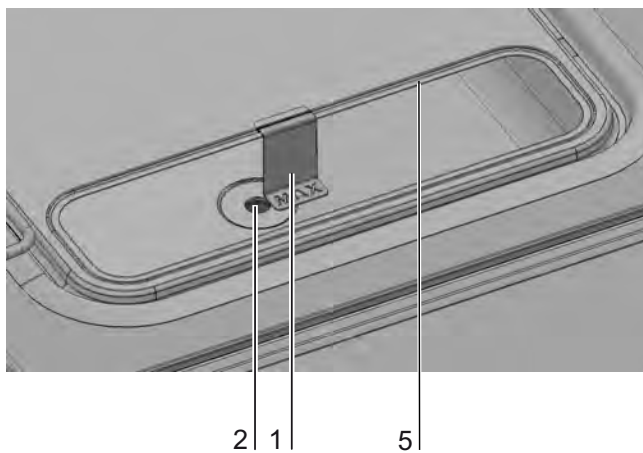

**Figure 5-3.** “MAX” fill level indicator

7. Wipe the excess water from the lid of the water reservoir.
8. Re-insert the pre-filter ([Figure 5-1](#), 2).
9. Re-insert the lower insert shelf or close the flap of the filling cut-out.
10. Make sure that the valves of the CO<sub>2</sub>/O<sub>2</sub>/N<sub>2</sub> gas supply system are open.
11. Switch on the device at the power switch.
12. Adjust the set values for temperature and CO<sub>2</sub>/O<sub>2</sub> content on the iCAN2.0™ Touch Screen.

## Starting the device

### Note

Duration of the auto-start routine

When the device is cold and when the ambient temperature is low, the auto-start routine may take up to 10 hours.

- Start the device with auto-start (see "[Activating auto-start](#)" on [Page 6-11](#)).

The auto-start progress indicator appears on the display, and the automatic start routine is run.

The temperature control adjusts the temperature to the selected set value, and humidity builds up.

When temperature and relative humidity are constant, automatic adjustment of the CO<sub>2</sub>/O<sub>2</sub> measurement system takes place.

The CO<sub>2</sub>/O<sub>2</sub> control supplies gas to the CO<sub>2</sub>/O<sub>2</sub> set value.

If the auto-start routine has been completed, the progress indicator fades out, and the main menu is displayed. The device is ready for operation.

## Loading the device

### Note

Loading

To ensure sufficient air circulation and even heating of the cultures, the loading surface in the workspace should be used up to a maximum of 70%. Objects with a large area or devices which emit heat in the workspace can impair heat distribution. Objects with a large area or devices which emit heat in the workspace can impair heat distribution.

- Load the work space with cultures.

# Handling

## Contents

- "Power switch" on Page 6-2
- "Operating panel and operating screen layout" on Page 6-3
- "Explanation of icons" on Page 6-4
- "Heating phase of the control loop sensors" on Page 6-5
- "Behavior of keys in settings" on Page 6-6
- "Setting the temperature set value" on Page 6-7
- "Adjusting the CO2 set value" on Page 6-7
- "Adjusting the O2 set value" on Page 6-8
- "Adjusting humidity" on Page 6-10
- "Auto-start function" on Page 6-11
- "Launching Steri-Run" on Page 6-14
- "User configuration" on Page 6-15
- "Error messages" on Page 6-46
- "Action after power failure" on Page 6-49

## Power switch

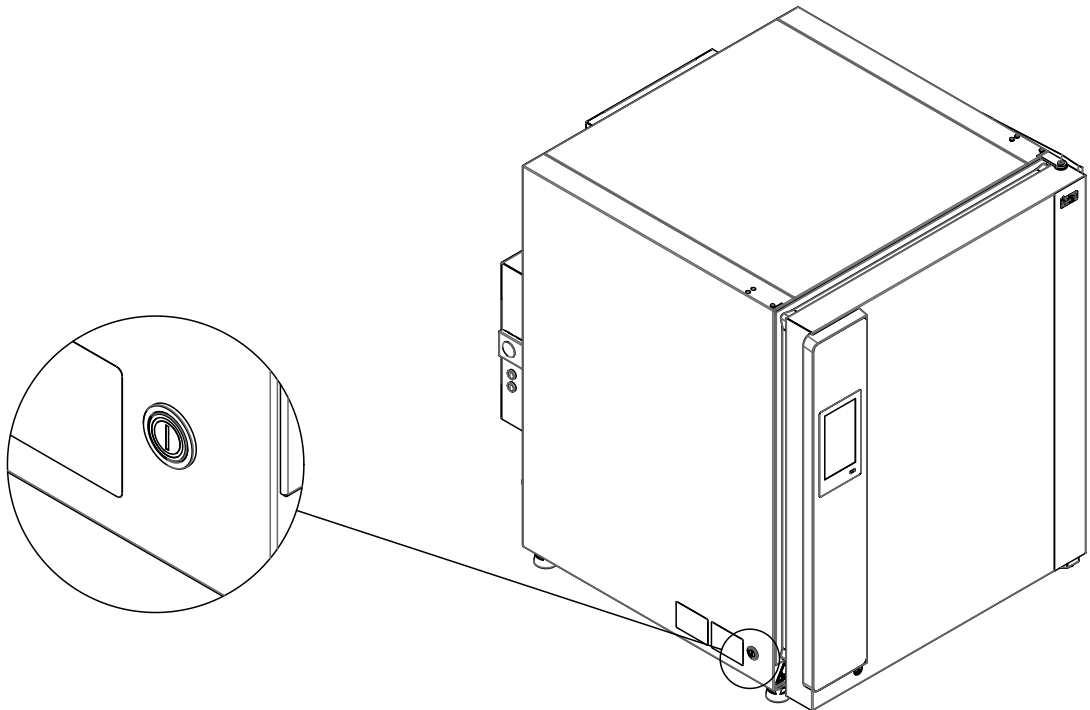

**Figure 6-1.** Power switch

The power switch is mounted in the side panel of the unit.

- Powering up: Press the power switch; the switch lights up.
  - After a short beep and a short blank screen phase, the touchscreen is displayed.
  - The sensors in the control loops go through the heating phase ("[Heating phase of the control loop sensors](#)" on [Page 6-5](#)).
- Powering down: Press the power switch; the switch light goes out.

## Operating panel and operating screen layout

The operating panel works as a touchscreen (iCan2.0™ Touchscreen) and can be operated with light pressure using a finger (even wearing gloves) or a blunt pen.



**Figure 6-2.** Start screen: Touch-sensitive screen areas

The following screen areas of the operating panel are touch-sensitive and accept operating commands:

- Menu key  top right
- Temperature display field
- CO<sub>2</sub> display field
- RH display field
- O<sub>2</sub> display field
- Steri-run key
- Auto-start key

### Note

Extended touch-sensitive area

To confirm an error message, the entire touchscreen can be used as a touch-sensitive area.

## Explanation of icons

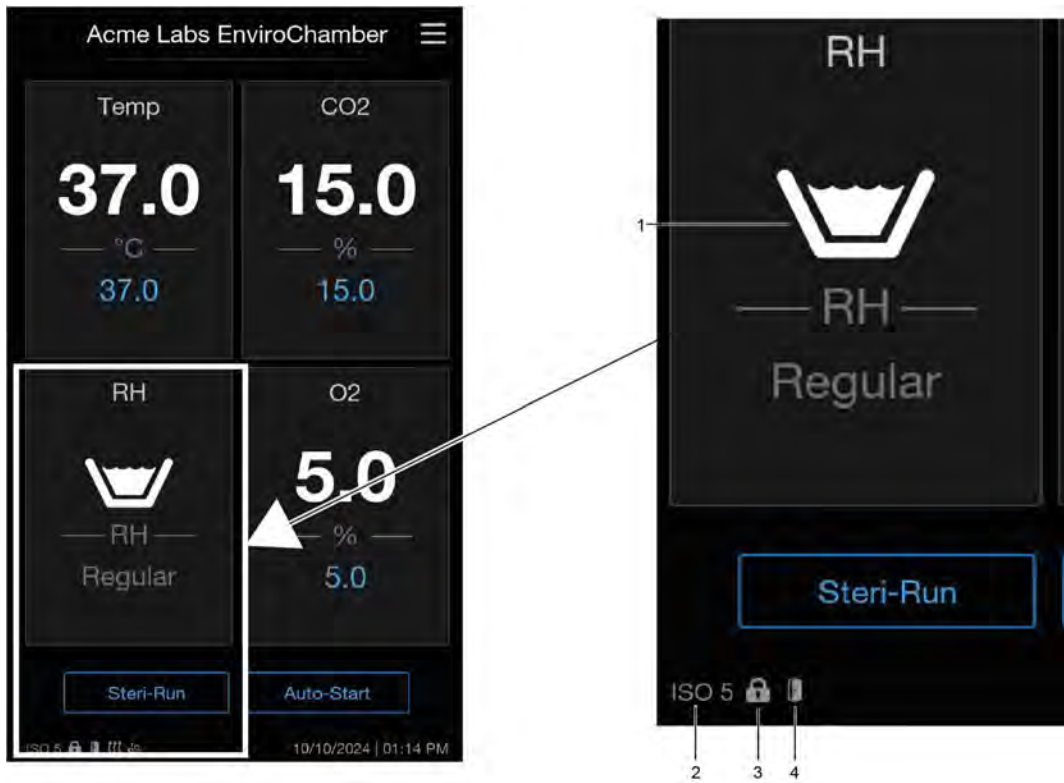



Figure 6-3. Explanation of icons

Pos.	Icon	Meaning
1		Water level above the minimum
-		Water level too low
-		No water - dry
2		HEPA filter activity indicator

Pos.	Icon	Meaning
3		Keypad lock activated
4		Door open

## Default settings of the controls

Upon delivery, the devices are preset to the following set values:

- Temperature: 37°C (98.6 °F)
- CO<sub>2</sub> content 0.0 % (is adjusted by the customer)
- O<sub>2</sub> content (optional): 21.0 %

### Note

CO<sub>2</sub>/O<sub>2</sub> control:

Since the CO<sub>2</sub> concentration of the air is close to 0%, the CO<sub>2</sub> control and the control loop error monitoring are deactivated at a set value of 0%.

Since the O<sub>2</sub> concentration of the air is 21%, the O<sub>2</sub> control and the control loop error monitoring are deactivated at a set value of 21%.

## Heating phase of the control loop sensors

When the device has been switched on, the control loop sensors pass through a heating phase of varying duration during the start-up process:

- Temperature control loop: 10 s
- CO<sub>2</sub> sensor heating period (WLD and IR): 5 min.
- O<sub>2</sub> control loop: 5 min.

The start-up process is indicated by an acoustic signal. During the heating phase, dots (...) are shown instead of values in the following display fields:

- Temperature display field,
- CO<sub>2</sub> display field, and
- O<sub>2</sub> display field

## Handling

### Behavior of keys in settings

After the heating phase has been completed, the control loop actual values are indicated.

#### Note

##### CO<sub>2</sub> gassing

During the 5-minute heating phase of the O<sub>2</sub> control loop, the CO<sub>2</sub> supply to the workspace and monitoring of the CO<sub>2</sub> control loop are suspended.

## Behavior of keys in settings

Pressing a key can gradually increase or reduce a value:

- Keeping the “–” or “+” key depressed switches to rapid run-through mode,
- and after approx. 3 s, the speed of the rapid run-through is additionally increased.

#### Note

##### Saving the settings

To save changed values, confirm by pressing the Enter key.

##### Resetting the settings:

Unless a user action (contact with the touch-sensitive areas and keys) occurs within 30 seconds, the system automatically exits the menu, and the most recently confirmed setting is applied.

## Setting the temperature set value

1. Press the temperature display field.  
The temperature menu (Figure 6-4) is displayed.

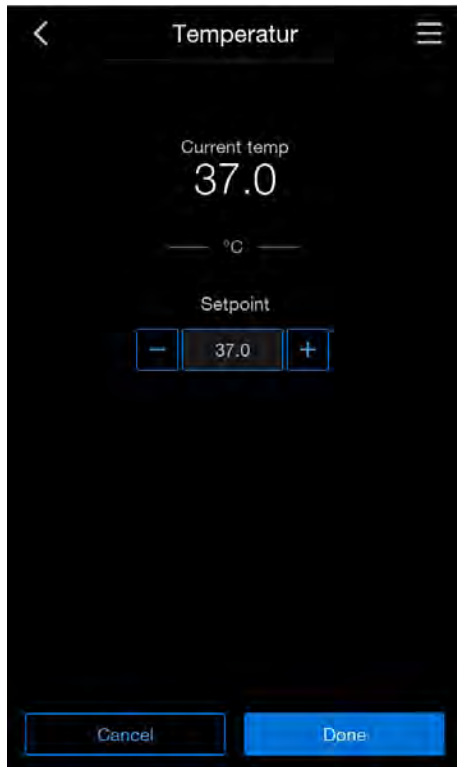

**Figure 6-4.** Temperature selection menu

2. Adjust the temperature set value using the “+” and “-” keys.
3. Press the “Done” key to apply the new set value.  
You will be taken back to the start screen.
4. If you do not want to make any changes, press the "Cancel" key to leave the menu and return to the start screen.

## Adjusting the CO<sub>2</sub> set value

1. Press the CO<sub>2</sub> display field.  
The CO<sub>2</sub> menu (Figure 6-4) is displayed.



**Figure 6-5.** CO<sub>2</sub> selection menu

2. Adjust the CO<sub>2</sub> set value using the “+” and “-” keys.
3. Press the “Done” key to apply the new set value.  
You will be taken back to the start screen.
4. If you do not want to make any changes, press the "Cancel" key to leave the menu and return to the start screen.

**Note**

Deactivating the CO<sub>2</sub> control loop:

To deactivate the CO<sub>2</sub> control, the set value is adjusted to 0%. If the control loop is deactivated, error monitoring is also disabled.

**Note**

Ventilate the internal chamber after the change of CO<sub>2</sub> set value if the new CO<sub>2</sub> set value is lower, so that no alarm message occurs.

## Adjusting the O<sub>2</sub> set value

1. Press the O<sub>2</sub> display field.  
The O<sub>2</sub> menu ([Figure 6-4](#)) is displayed.

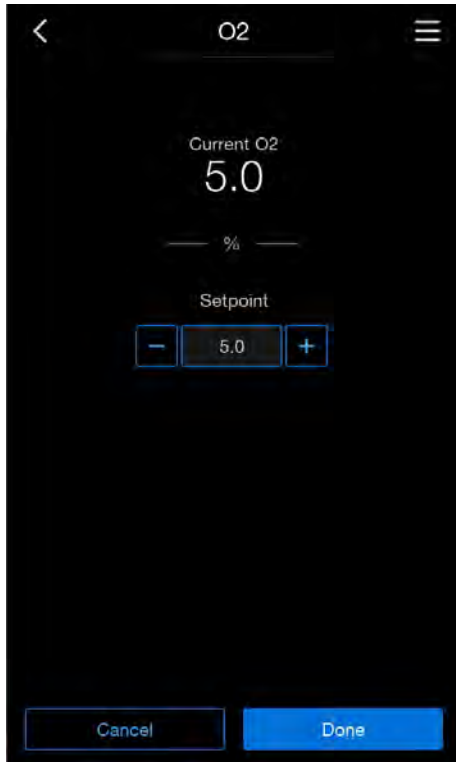

**Figure 6-6.** O<sub>2</sub> selection menu

2. Adjust the O<sub>2</sub> set value using the “+” and “-” keys.
3. Press the “Done” key to apply the new set value.  
You will be taken back to the start screen.
4. If you do not want to make any changes, press the "Cancel" key to leave the menu and return to the start screen.

### Note

Ventilate the internal chamber after the change of O<sub>2</sub> set value so that no alarm message occurs.

### Note

Default settings

Depending on the type of O<sub>2</sub> sensor, one of the two O<sub>2</sub> control ranges is preset at the factory:

Control range I: 1% - 21%

Control range II: 5% - 90%

Use of the process gases

- For set values below 21 % O<sub>2</sub>, connect the device to a nitrogen supply.
- For set values above 21 % O<sub>2</sub>, connect the device to an oxygen supply.

For set values of 21 % O<sub>2</sub>, the control loop is deactivated, i.e. error monitoring is also disabled.

## Adjusting humidity

If condensation occurs on the culture containers due to high relative humidity, the humidity in the workspace can be set to a lower level. Device control is preset at the factory to regular - approx. 93% relative humidity.

1. Press the RH display field.

The "humidity mode" menu (Figure 6-7) is displayed.

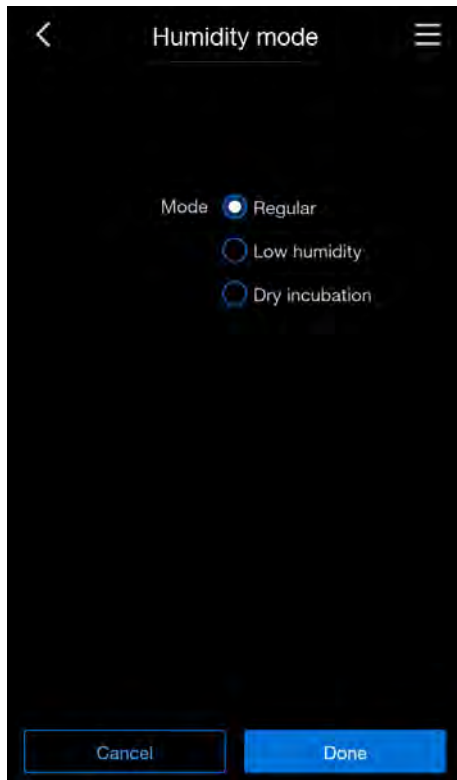

**Figure 6-7.** "Humidity mode" menu

2. Select the extent to which you wish to regulate the humidity. Choose between:
  - Regular (humidity is 93%)
  - Low humidity (humidity is reduced to 90%)
  - Dry incubation (little humidity)

### Note

The "Dry Incubation" function is specially intended for applications that already contain media and water (e.g. "Cell Factory System").

Precise temperature controls ensure that the cultures are incubated under constant and dry conditions, which increases the reliability and reproducibility of the results.

3. Apply and save the change by pressing the "Done" key.

You will be returned to the start screen.

After returning to the start screen, the selected option appears in the RH display field.

# Auto-start function

## CAUTION

Please make sure that the O<sub>2</sub> sensor has been correctly plugged into the socket. Incorrect installation of the sensor may lead to corrosion at the contacts and calibration errors during the auto-start routine. You can verify correct function by simply activating the sensor. If no error message occurs within 10 minutes, the unit is ready for the auto-start routine.

The auto-start function is an automated routine for start-up and subsequent adjustment of the CO<sub>2</sub> measurement system. After start-up, the device control adjusts the temperature set value. Moisture builds up at the same time. When temperature and relative humidity have reached constant values, the CO<sub>2</sub> measuring system is automatically adjusted to these values, and the workspace is supplied with the preset quantity of CO<sub>2</sub>.

## Auto-start routine aborted due to error:

The auto-start routine is aborted if:

- an error is detected in the temperature control loop,
- an error is detected in the CO<sub>2</sub> control loop,
- the water level is too low,
- the CO<sub>2</sub> value to be set is out of tolerance.

## Dry execution of auto-start routine:

If the auto-start routine is to be executed dry - without water filling in the water reservoir of the work space - the water sensor must be deactivated (Chapter "[Switching water sensor on/off](#)" on [Page 6-17](#)).

## Activating auto-start

### Preparations for start-up

1. Make sure that the valves of the CO<sub>2</sub>/O<sub>2</sub>/N<sub>2</sub> gas supply system are open.
2. Pour sterilized distilled water into the water reservoir of the work space. Do not exceed the maximum level mark.

### Launching the auto-start routine

1. Press the "Auto-start" key.

The "auto-start sequence" menu is displayed.



**Figure 6-8.** Activating auto-start

2. If you do not want to make any changes, press the "End" key to leave the menu and return to the start screen.
3. If you want to perform an auto-start, press the "Start" key.
4. Open the door until the acoustic signal sounds (approx. 30 s)
5. Add water if necessary.
6. Close the door.

A status display window showing data on the process is displayed:

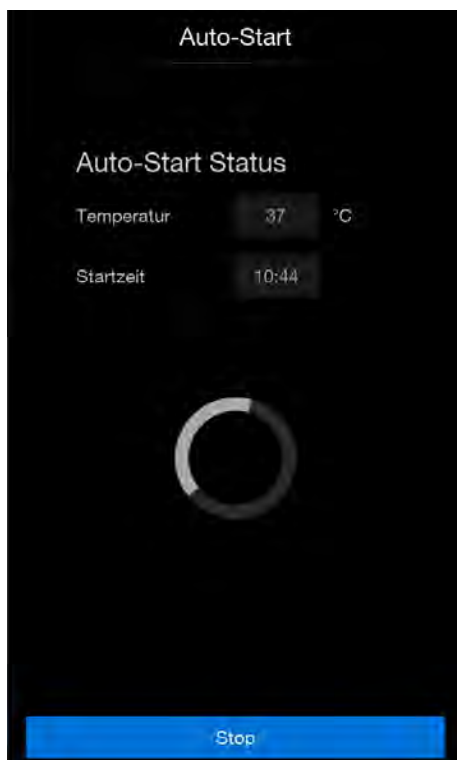

**Figure 6-9.** Auto-start status display

7. If you want to abort the Auto-Start, press the “Stop” key.  
The “Abort Auto-Start” menu appears ([Figure 6-10](#)).

## Aborting auto-start

### Note

#### Abort

The Auto-Start routine can be interrupted at any time by pressing the “Stop” key.

#### Automatic restart:

The Auto-Start routine is restarted automatically if the routine is aborted due to one of the following events:

- the glass door is opened,
- the outer door with an optional segmented inner door is opened,
- the power supply is interrupted

If the "Stop" key in the status display is pressed, the auto-start routine is interrupted and the "Auto-Start Stop" dialog window is displayed as a confirmation prompt. The routine can now be permanently canceled or resumed.

1. To continue Auto-Start, press the "Back" key.  
You are returned to the start screen, and the auto-start routine is resumed.
2. To abort Auto-Start, press the "End" key.

The warning triangle is displayed together with the acoustic signal.



**Figure 6-10.** Aborting auto-start

## Launching Steri-Run

Steri-Run is an automated sterilization cycle for sterilizing the device workspace. The Steri-Run sterilization cycle uses an automated program sequence to decontaminate the complete workspace including the shelf system and the sensors. A detailed sequence of the device function is described in the chapter Cleaning and disinfection ("[Steri-Run sterilization cycle](#)" on [Page 8-5](#)).

## User configuration

The user configuration settings allow you to adjust the user interface and the additional device functions to the requirements of everyday operation. The selection menu for user configuration (Figure 6-11) is accessed via the start screen menu key (Figure 6-2).

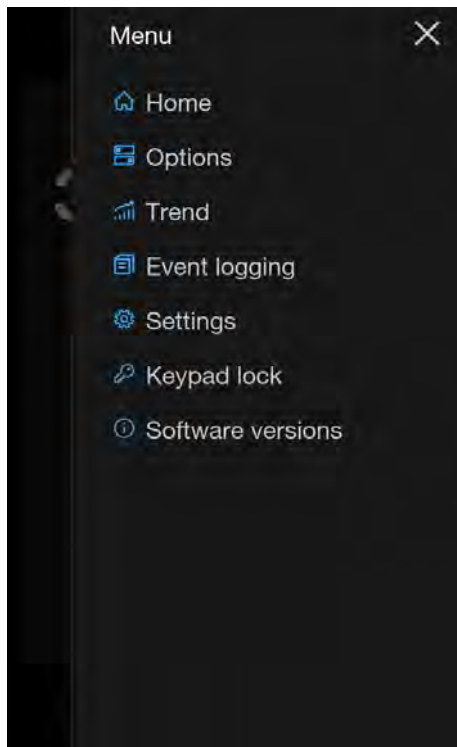

**Figure 6-11.** User configuration menu

The user configuration menu is organized into six categories:

- Start (return to start screen)
- Options
- Trend
- Data logging
- Settings/Setup
- Keypad lock
- Software versions

Make a user-specific setting in a dialog box by navigating through the sub-menus indicated in the figures and then calling up the dialog box.

## Options

The "Options" selection menu (Figure 6-12) permits access to all settings dialogs for the functional options of the device:

- Water sensor
- HEPA configurations
- Door configurations
- O<sub>2</sub> configurations

1. Press the "Menu" key on the start screen (Figure 6-2).
2. The "User configuration" menu appears.
3. Select the "Options" menu command.

The "Options" selection menu appears:

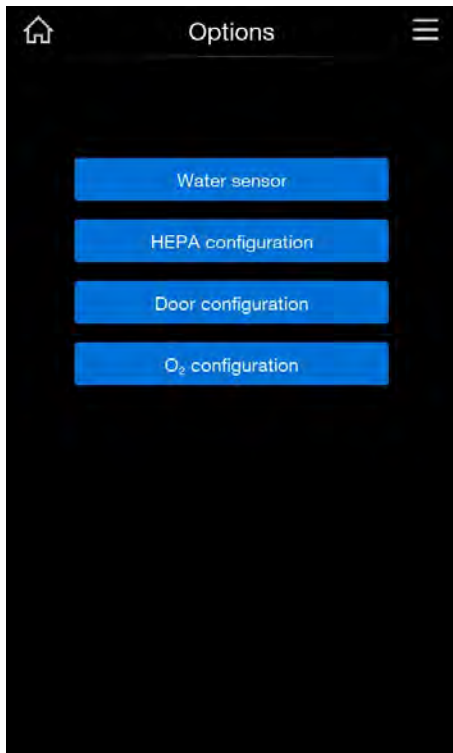

**Figure 6-12.** Options selection menu

## Switching water sensor on/off



### CAUTION

When the water sensor is switched off, the Steri-Run routine can be started despite the presence of water in the water reservoir. This is incorrect use and may destroy the fan motor.

1. Press the “Menu” key on the start screen (Figure 6-2).
2. The “User configuration” menu appears.
3. Select the “Options” menu command
4. Select the “Water sensor” option.

The “water sensor” selection menu appears:

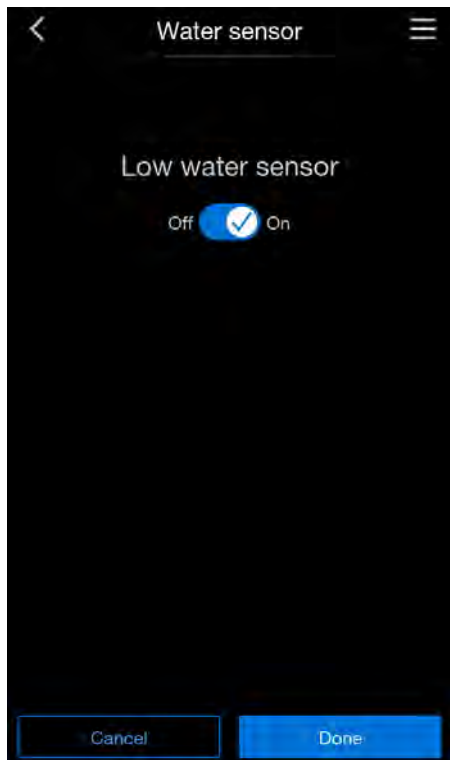

**Figure 6-13.** Switching water sensor on/off

5. Switch the water sensor on or off as needed.
6. Press “Cancel” to return to the “Options” menu without changes.
7. Press “Done” to apply the changed setting. You will then return to the “Options” menu.

By deactivation of the water sensor and adjustment of the humidity, the relative humidity in the work space can be lowered.

The change requires an extended adaptation phase. To ensure that it effectively prevents condensation on culture containers, it must be used as a permanent setting.

For incubation operation with ambient humidity or if the auto-start routine is to be run dry (without water), the water sensor can be switched off. This prevents water sensor alarm messages from the control system in the device.

If the "Dry Incubation" function is selected, the water sensor is automatically deactivated.

**Note**

Water sensor off

The on/off switching of the water sensor is entered in the event list.

## HEPA configuration

### Note

The incubator is optimized for operation with a HEPA filter.

If you do not use a HEPA filter, the specified properties of the device may not be reached.

1. Press the “Menu” key on the start screen (Figure 6-2).
2. The “User configuration” menu appears.
3. Select the “Options” menu command
4. Select the “HEPA configuration” option.

The “HEPA configuration” selection menu appears:

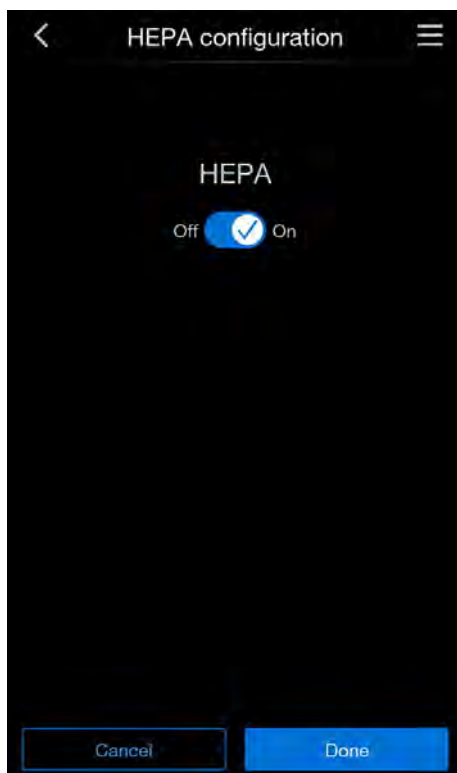

**Figure 6-14.** HEPA configuration menu

5. Switch the HEPA option on or off as needed.
6. Press “Cancel” to return to the “Options” menu without changes.
7. Press “Done” to apply the changed setting. You will then return to the “Options” menu.

## Door configuration

### Segmented inner door

Since the opening cross-sections are smaller when accessing the cultures, devices equipped with the optional segmented inner door achieve shorter recovery times of the incubation parameters:

- Work space temperature
- CO<sub>2</sub> concentration
- O<sub>2</sub> concentration
- Relative humidity

After conversion of the device, the device control must be switched to the segmented inner door option.

In the “Segmented inner door” menu, you can choose whether your device has a glass door or a segmented inner door.

#### Note

Malfunction:

The conversion to a segmented inner door results in a change in the control parameters.

If the “Segmented inner door” function is not set to the door variant actually installed, this can lead to malfunctions in incubation.

### Selecting door type

1. Press the “Menu” key on the start screen ([Figure 6-2](#)).
2. The “User configuration” menu appears.
3. Select the “Options” menu command
4. Select the “door configuration” option.

The “Door configuration” selection menu appears:

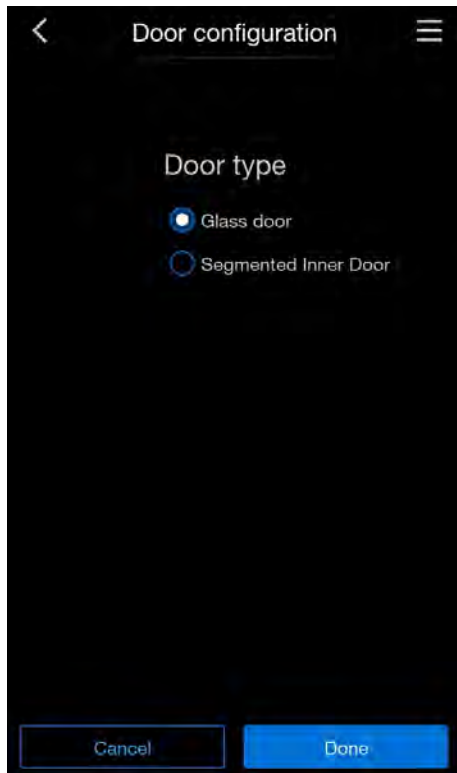

**Figure 6-15.** Door configuration menu

5. Select the applicable door type.
6. Press “Cancel” to return to the “Options” menu without changes.
7. Press “Done” to apply the changed setting. You will then return to the “Options” menu.

## O<sub>2</sub> configuration

1. Press the “Menu” key on the start screen ([Figure 6-2](#)).
2. The “User configuration” menu appears.
3. Select the “Options” menu command
4. Select the “O<sub>2</sub> configuration” option.

The “O<sub>2</sub> configuration” selection menu appears:

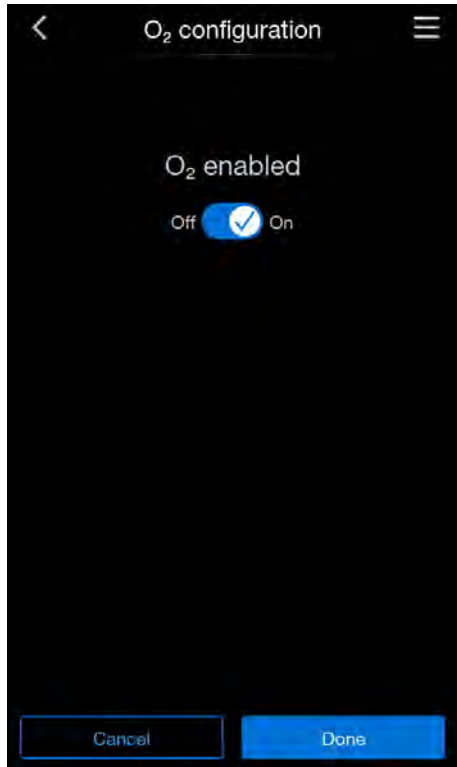

**Figure 6-16.** O<sub>2</sub> configuration menu

5. Switch the O<sub>2</sub> option on or off as needed.
6. Press “Cancel” to return to the “Options” menu without changes.
7. Press “Done” to apply the changed setting. You will then return to the “Options” menu.

**Note**

If the device is operated with O<sub>2</sub> or N<sub>2</sub>, the workspace must be ventilated after the O<sub>2</sub> control is switched off.

## Trend

The “trend” view shows a graphic overview of the temperature, CO<sub>2</sub>, and O<sub>2</sub> course of the last 12, 24, and 72 hours.

1. Press the “Menu” key (Figure 6-2).
2. Select the “Trend” menu command

The “Trend” graphic overview appears:

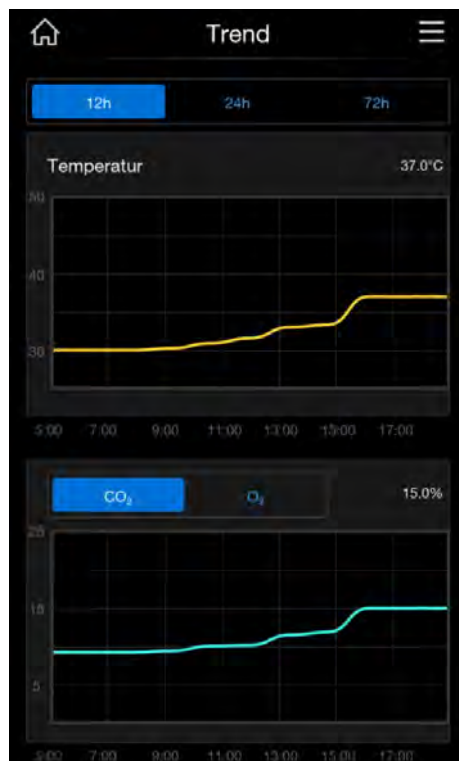

**Figure 6-17.** “Trend” graphic overview

3. Select the period for which you wish to see a graphic representation of the course by selecting the corresponding option. The following are available:
  - 12 h
  - 24 h
  - 72 h
4. Select whether you want to see the course curve for CO<sub>2</sub> or O<sub>2</sub>.
5. Click on the home symbol, top left.

You will be returned to the start screen.

## Data logging

The Data logging selection menu (Figure 6-18) permits access to dialogs for logging and displaying events during device operation:

- Event display
- Error table

- Reminder
- 1. Press the “Menu” key on the start screen ([Figure 6-2](#)).  
The “User configuration” menu appears.
- 2. Select the “Data logging” menu command.  
The “Data logging” selection menu appears:

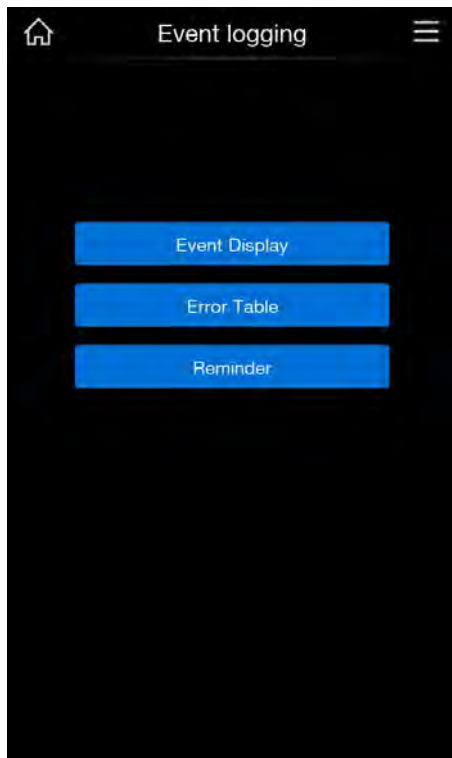

**Figure 6-18.** Data logging menu

## Event display

The event display uses short, single-line entries indicating the date and time to report the events logged during operation of the device.

The entries are listed in chronological order with the most recent event at the top. The list can be viewed but not edited. If the event display consists of several pages, the user can browse through the list. The status display indicates which page of the total number of pages is currently being displayed.

1. Press the "Menu" key.
2. Select the “Data logging” menu command.
3. Select the “Event display” menu command.

The list shown in [Figure 6-19](#) appears.



The screenshot shows a mobile application interface titled "Event Display". It features a list of events with two columns: "Time" and "Process". The events are listed in descending chronological order. At the bottom of the screen, there are two buttons: "Back" and "Done".

Time	Process
14.02.25 13:42	CO2 set value changed
14.02.25 13:27	New error CO2
14.02.25 13:12	New error RH
14.02.25 12:57	Power reset
14.02.25 12:42	Temp set value changed
14.02.25 12:27	New error system
14.02.25 12:12	CO2 set value changed
14.02.25 11:57	Power reset
14.02.25 11:42	CO2 set value changed
14.02.25 11:27	New error T
14.02.25 11:12	Temp set value changed
14.02.25 10:57	Power reset
14.02.25 10:42	New error RH

**Figure 6-19.** Displaying events

4. Press the "End" or "Back" key to reach the "Data logging" selection menu.

## Error table

The error table lists the errors detected by the device-internal control system in descending chronological order. The most recently detected error is listed at the top of 22 possible entries. An entry consists of the control loop in which the error occurred, the date, the time, and an error description. The error table can be viewed but not edited. If the event display consists of two pages, the user can browse through the list. The status display 001/002 or 002/002 indicates which of the two pages is currently being displayed.

1. Press the "Menu" key.
2. Select the "Data logging" menu command.
3. Select the "Error table" menu command.

The list shown in [Figure 6-20](#) appears.

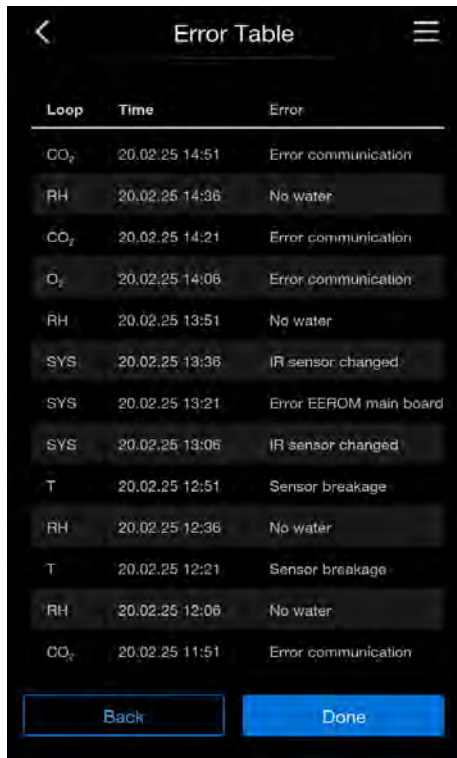

Loop	Time	Error
CO <sub>2</sub>	20.02.25 14:51	Error communication
RH	20.02.25 14:36	No water
CO <sub>2</sub>	20.02.25 14:21	Error communication
O <sub>2</sub>	20.02.25 14:06	Error communication
RH	20.02.25 13:51	No water
SYS	20.02.25 13:36	IR sensor changed
SYS	20.02.25 13:21	Error EEPROM main board
SYS	20.02.25 13:06	IR sensor changed
T	20.02.25 12:51	Sensor breakage
RH	20.02.25 12:36	No water
T	20.02.25 12:21	Sensor breakage
RH	20.02.25 12:06	No water
CO <sub>2</sub>	20.02.25 11:51	Error communication

**Figure 6-20.** Viewing the error table

**Note**

Error handling

For a detailed overview of causes of errors and their correction, refer to the end of this chapter.

4. Press the “Done” or “Back” key to reach the “Data logging” selection menu.

**Reminder**

The set reminder intervals are shown in the “Reminder” list display.

1. Press the "Menu" key.
2. Select the “Data logging” menu command.
3. Select the “Reminder” menu command.

The list shown in [Figure 6-20](#) appears.

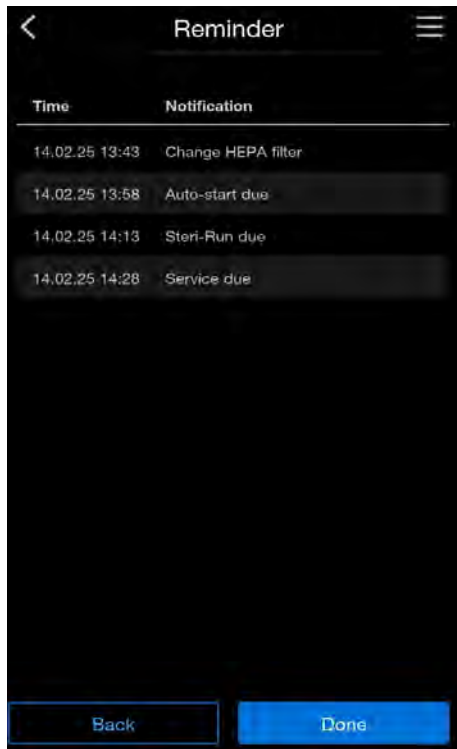

**Figure 6-21.** Reminder list display

## Settings

The Settings selection menu (Figure 6-22) permits access to a series of dialog windows with settings options for individual configuration of the user interface:

- Keypad lock code
- Display
- Alarm
- Reminder intervals
- Calibration
- Logging cycle time
- Service level

1. Press the “Menu” key on the start screen (Figure 6-2).

The “User configuration” menu appears.

2. Select the “Settings” menu command.

The “Settings” selection menu appears:

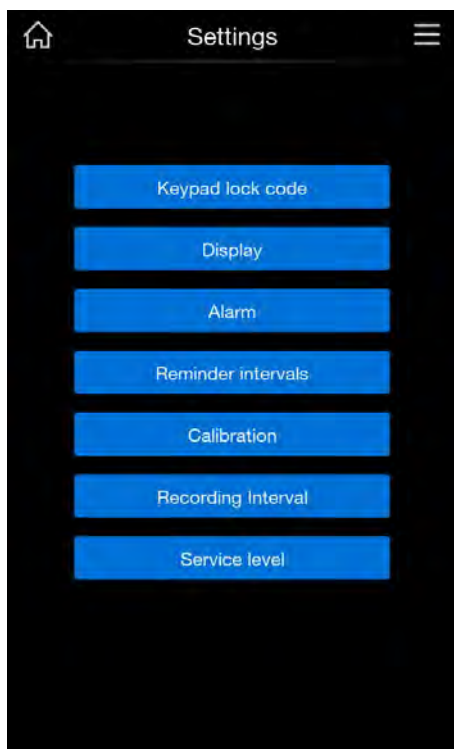

Figure 6-22. Settings menu

## Changing the keypad lock code

### Note

Resetting the code

If the keypad lock code is no longer available, the code must be reset to the standard code by Thermo Fisher Scientific Technical Support.

The keypad lock prevents unauthorized modification of the operating settings. Only those keys used to enter values are locked.

The keypad code consists of four numbers.

The default code is: 0000.

This default can be changed to a user-defined code that is then activated using the KEYPAD LOCK dialog window ("Keypad lock" on [Page 6-44](#)).

1. Press the "Menu" key ([Figure 6-2](#)).
2. Select the "Settings/Setup" menu command
3. Select the "Keypad lock code" menu command.

The input dialog shown in [Figure 6-23](#) appears:

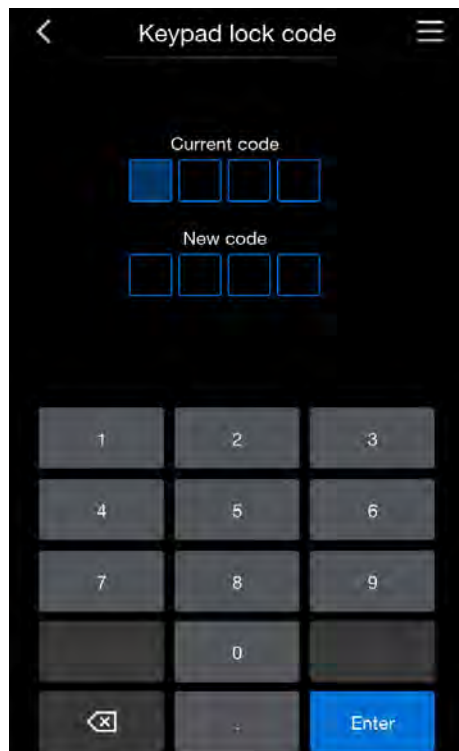

**Figure 6-23.** Changing the keypad lock code

4. Enter the factory default code 0000 by pressing the corresponding number keys.
5. Now enter the desired new code.
6. Press the "Enter" key

The screen returns to the "Settings/setup" menu.

The lock symbol appears in the icon bar in the main menu ([Figure 6-2](#)) as an activity display for the keypad lock.

### **Note**

Changing the user-defined code

The user-defined code can be changed as often as required using the same procedure:

- Activate the new code by entering the valid code,
- Enter the new code, and confirm.

## **Display**

The "Display" selection menu ([Figure 6-24](#)) permits access to a number of input dialogs with settings options for individual configuration of the user interface:

- Brightness
  - Language
  - Date/time
  - Key tone
1. Press the "Menu" key ([Figure 6-2](#)).
  2. Select the "Settings/Setup" menu command
  3. Select the "Display" menu command.

The input dialog shown in [Figure 6-24](#) appears:

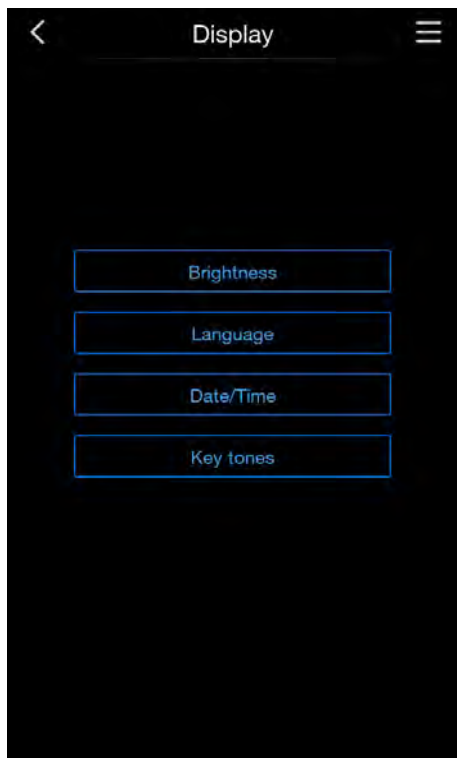

**Figure 6-24.** Display selection menu

### **Adjusting display brightness**

The input dialog makes it possible to adjust the brightness of the operating panel in a range of 1 through 100%.

1. Press the "Menu" key ([Figure 6-2](#))
2. Select the "Settings" menu command.
3. Select the "Display" menu item.
4. Select the "Brightness" option.

The input dialog shown in [Figure 6-25](#) appears:

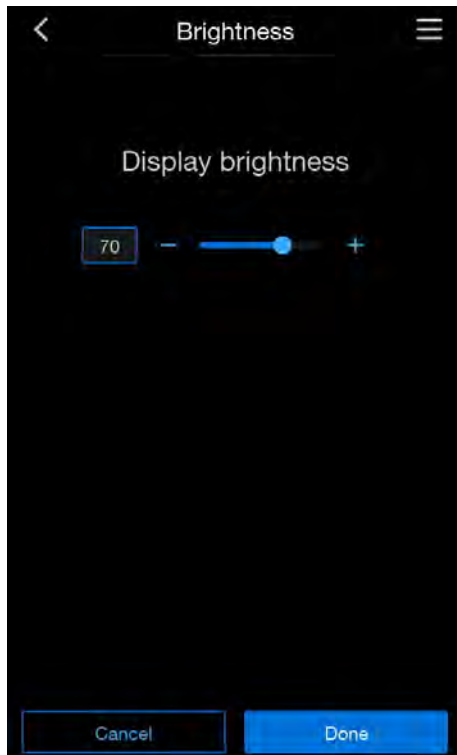

**Figure 6-25.** Adjusting display brightness

- Press the "+" key to increase the value.
- Press the "-" key to decrease the value.
- Press "Done" to apply the value.

The screen returns to the "Display" selection menu.

- Press "Cancel" to leave the "Display brightness" menu without any changes.

### Setting the language of the user interface

The input dialog makes it possible to set the language of the user interface. Seven languages are available:

- English
- German
- Italian
- French
- Spanish
- Japanese
- Chinese (Mandarin)

1. Press the "Menu" key ([Figure 6-2](#)).
2. Select the "Settings/Setup" menu command.
3. Select the "Display" menu command
4. Select the "Language" menu command

The input dialog shown in [Figure 6-26](#) appears.



**Figure 6-26.** Setting the language

1. Select the desired language by pressing the corresponding key.  
The language of the current display changes to the desired language.
2. Press "Done" to confirm your selection.
3. If you do not wish to make any change, press the "Cancel" key.  
The screen returns to the "Display" selection menu

### Setting the date/time

The input dialog makes it possible to set date and time to the desired time zone.

1. Press the "Menu" key ([Figure 6-2](#)).
2. Select the "Settings" menu command
3. Select the "Display" menu command
4. Select the "Date/time" menu command.

The input menu shown in [Figure 6-27](#) appears:



**Figure 6-27.** Date/time selection menu

5. Enter the date using the number keys.
6. Apply and save the entry by pressing the “Enter” key.  
The system returns to the Date/time selection menu.
7. To change the time, select the option “Time”.

The input menu shown in [Figure 6-28](#) appears:

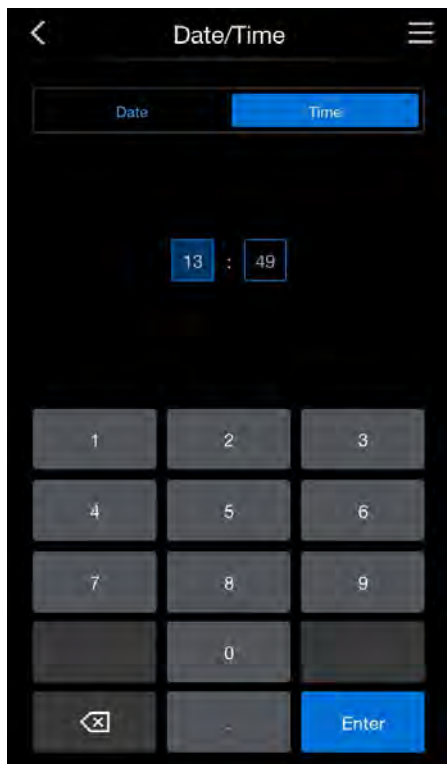

**Figure 6-28.** Setting the time

8. Enter the time with the number keys.
9. Apply and save the entry by pressing the "Enter" key.  
The system returns to the "Display" selection menu.

### Setting the key tone

1. Press the "Menu" key ([Figure 6-2](#)).
2. Select the "Settings" menu command
3. Select the "Display" menu command
4. Select the "Key tone" menu command.

The selection menu shown in [Figure 6-27](#) appears:

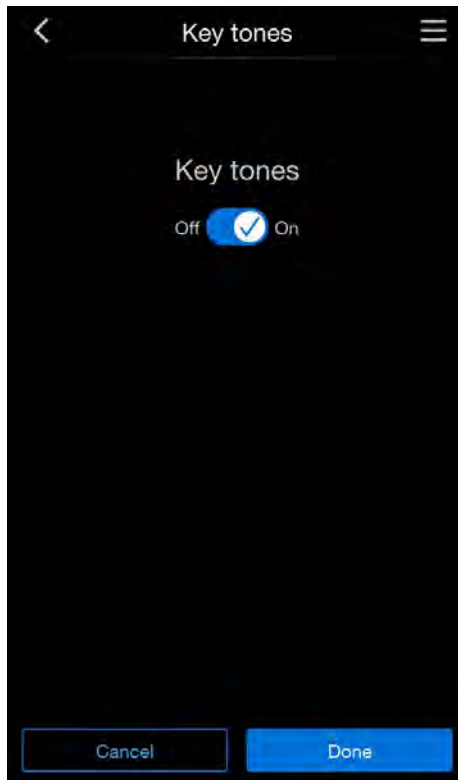

**Figure 6-29.** Key tone selection menu

5. Select whether you wish to enable the key tone.
6. Apply and save the entry by pressing the “Done” key.  
The system returns to the “Display” selection menu.
7. Press “Cancel” to return to the “Display” selection menu without any changes.

## Alarm

The alarm relay is the electrical interface connecting the device-internal control system to an external power supply monitoring system. Depending on the required input signal of the external monitoring system, power supply monitoring can be enabled or disabled. If power supply monitoring is enabled, a power failure is detected as an error. The wiring of the alarm relay is described in section ["Connecting the alarm contact"](#) on [Page 4-14](#).

1. Press the “Menu” key ([Figure 6-2](#)).
2. Select the “Settings” menu command
3. Select the “Alarm” menu command

The input dialog shown in [Figure 6-30](#) appears.

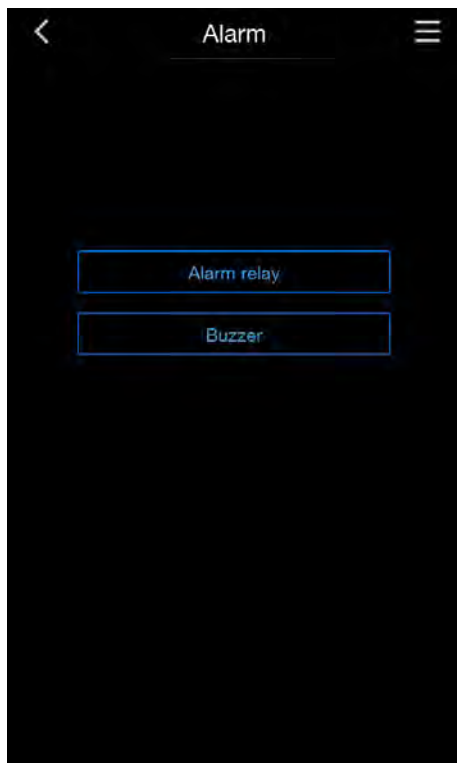

**Figure 6-30.** Alarm selection menu

### Selecting the alarm

1. Select the “Alarm relay” menu command.  
The selection menu shown in [Figure 6-31](#) appears.

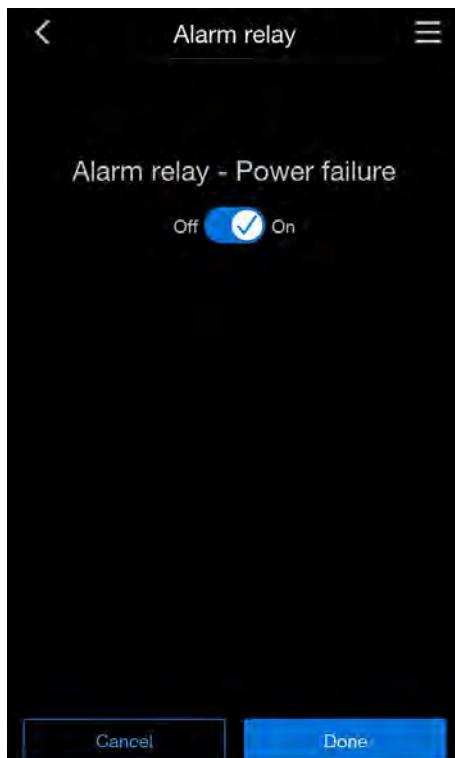

**Figure 6-31.** Setting the alarm relay

1. Choose whether you wish to switch the alarm relay power supply monitoring on or off.
2. Apply and save the change by pressing the "Done" key.  
The system returns to the "Alarm" selection menu.
3. Press "Cancel" to return to the "Alarm" selection menu without any changes.

### Selecting the buzzer

1. Select the "Buzzer" menu command.
2. Choose whether you wish to switch the buzzer on or off.
3. Apply and save the change by pressing the "Done" key.  
The system returns to the "Alarm" selection menu.
4. Press "Cancel" to return to the "Alarm" selection menu without any changes.

## Reminder intervals

The reminder intervals are integral components of the reporting and monitoring system of the device control. For the two major device functions Steri-Run and Auto-Start, as well as for routine service work, the user can set times on which a message is triggered. The count begins at 00:00 h of the day on which the preset reminder interval has elapsed.

On the due date, the display shows a reminder message for the activated reminder interval:

- Steri-Run: Please carry out Steri-Run.
- Auto-start: Please run auto-start. Appears after successful completion of the Steri-Run sterilization cycle.
- Service interval: Please carry out service. The service message can be confirmed. The Request Service icon is then displayed.
- HEPA interval and reset

After the routines have been run successfully, the reminder messages fade out.

### Default settings

Steri-Run sterilization cycle	90 days
Auto-start routine	Off
Service interval	Off
HEPA filter interval	365 days

### Setting reminder intervals

1. Press the “Menu” key ([Figure 6-2](#)).
2. Select the “Settings” menu command
3. Select the “Reminder intervals” menu command.

The selection menu shown in [Figure 6-32](#) appears.

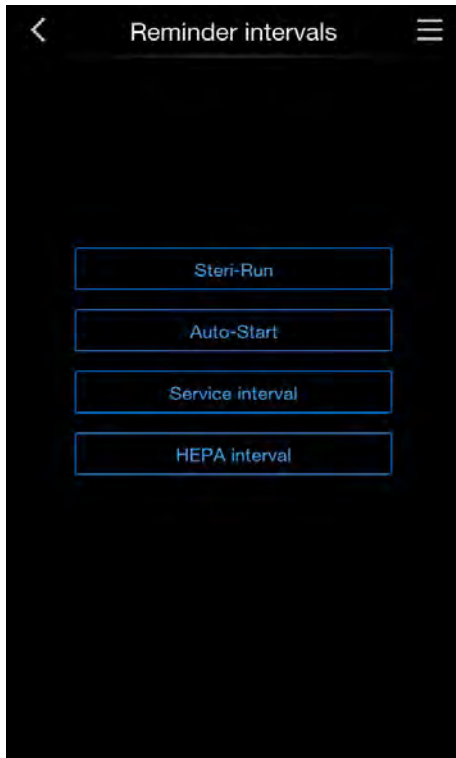

**Figure 6-32.** Reminder interval menu

4. Select the appropriate menu command, e.g. Steri-Run.  
The selection menu shown in [Figure 6-33](#) appears:

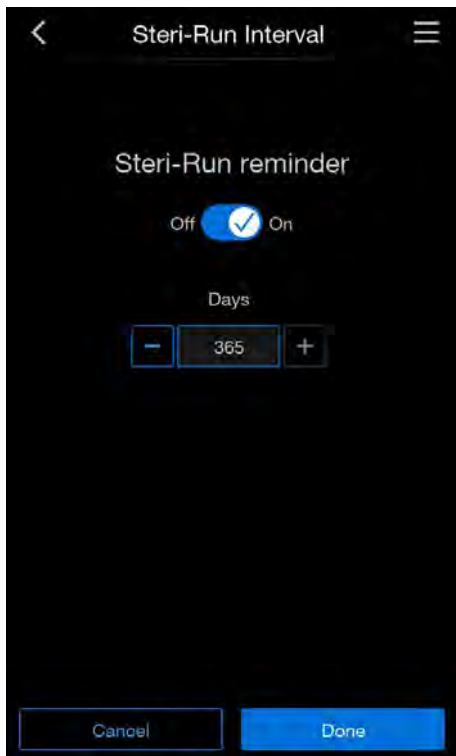

**Figure 6-33.** Setting the reminder interval for Steri-Run

1. Increase the number of days by pressing the + key.
2. Decrease the number of days by pressing the - key
3. Disable the reminder interval by setting the value to "Off".
4. Apply and save the change by pressing the "Done" key.
5. Press "Cancel" to return to the "Reminder intervals" selection menu without any changes.

The system returns to the "Reminder intervals" selection menu.

## **Calibration**

In the "Calibration" menu, you can calibrate the values for temperature and CO<sub>2</sub>.

For more information on this, please read the chapter "[Temperature calibration](#)" on [Page 9-3](#) and "[CO2 calibration](#)" on [Page 9-7](#).

## Logging cycle time

Due to limited memory resources, the oldest entries are deleted as new events are logged. The period from which the displayed events originate depends significantly on the selected logging cycle time.

Logging cycle	Maximum period displayed
10 s	22.5 hours
30 s	2.8 days
60 s	5.6 days
120 s	11.2 days
180 s	16.8 days
3600 s	336 days

The setting controls the logging cycle in sections of seconds during which the control loop measured values are logged during the operation of the device and displayed by the trend display.

The settings can be made within the value range of 10 s to 3600 s.

### Calling up logging cycle time

1. Press the "Menu" key.
2. Select the "Settings" menu command.
3. Select the "Logging cycle time" menu command.

The selection menu shown in [Figure 6-2](#) appears:

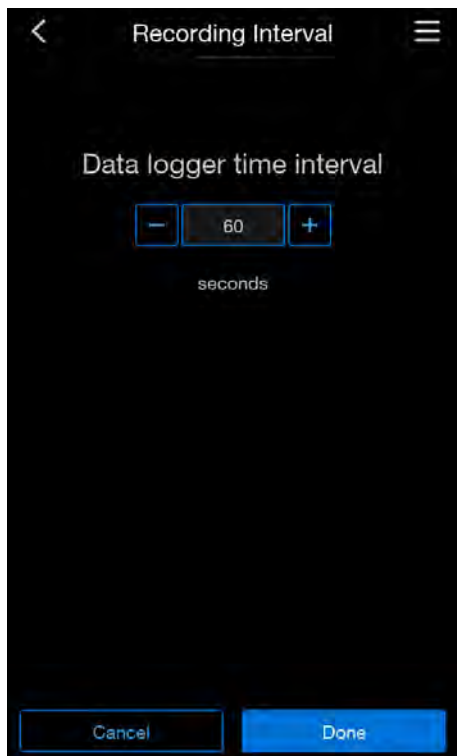

**Figure 6-34.** Logging cycle selection menu

### Setting the logging cycle time

1. Increase the value by pressing the + key.
2. Decrease the value by pressing the - key.
3. Apply and save the change by pressing the "Done" key.  
The system returns to the "Settings" selection menu.
4. Press "Cancel" to return to the "Settings" selection menu without any changes.

#### Note

Data logging cycles:

The logging cycle time does not affect the entries in the error table.

## Keypad lock

Deactivate or activate the keypad lock here with the code you previously set ("[Changing the keypad lock code](#)" on [Page 6-29](#)).

1. Press the "Menu" key.
2. Select the "Keypad lock" menu command.
3. Select the "Logging cycle time" menu command.

The input dialog shown in [Figure 6-2](#) appears:

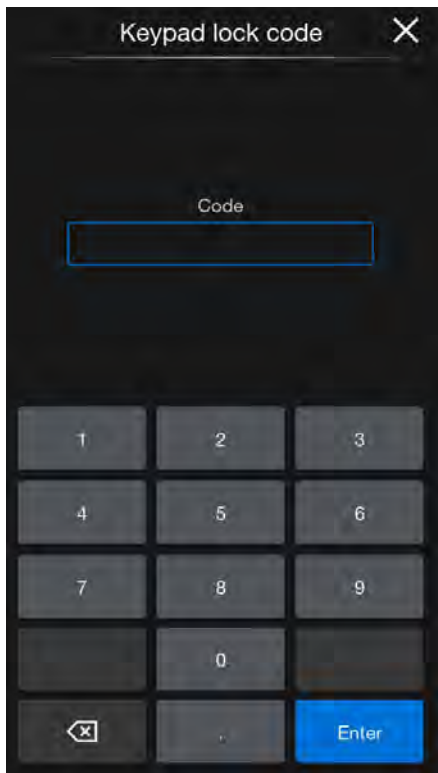

**Figure 6-35.** Keypad lock input dialog

1. Enter the applicable keypad lock code.
2. Apply and save the change by pressing the "Enter" key.

You will be returned to the start screen.

A red lock at the lower edge of the display on the start screen indicates that the keypad lock is active.

- To override the keypad lock, repeat the above steps.

The lock symbol on the display will disappear again.

## Software versions

The "Software versions" menu displays the versions of the software implemented to control the device.

1. Press the "Menu" key on the start screen ([Figure 6-2](#)).

2. Select the “Software versions” menu command.

The “Software versions” menu appears:



**Figure 6-36.** Software versions menu

3. Press “Done” to return to the start screen.

## Error messages

Error detection is part of the device-internal control system. It monitors the control loops, including their sensors. If an error is detected in the system, the alarm relay is switched and issues the following signals and messages:

- An acoustic alarm is issued as a two-tone buzzer sound,
- In the event of a temperature, CO<sub>2</sub>, O<sub>2</sub>, or humidity error, the relevant value is displayed highlighted in red on the start screen (Figure 6-39). As long as the error exists, you can continue to read it out by touching this field.
- If the door is opened, an info screen appears on which no further interaction is possible until the door is closed again:

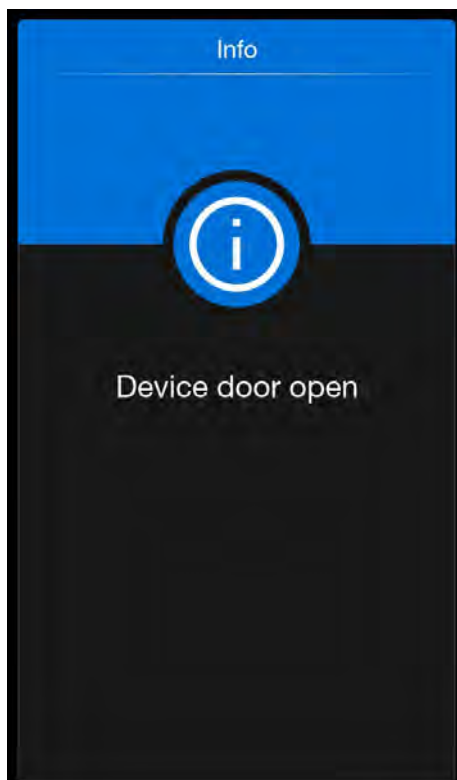

**Figure 6-37.** Device door open

- In the event of a system error or if the door is open too long, an alarm screen will appear on which the error is stated:

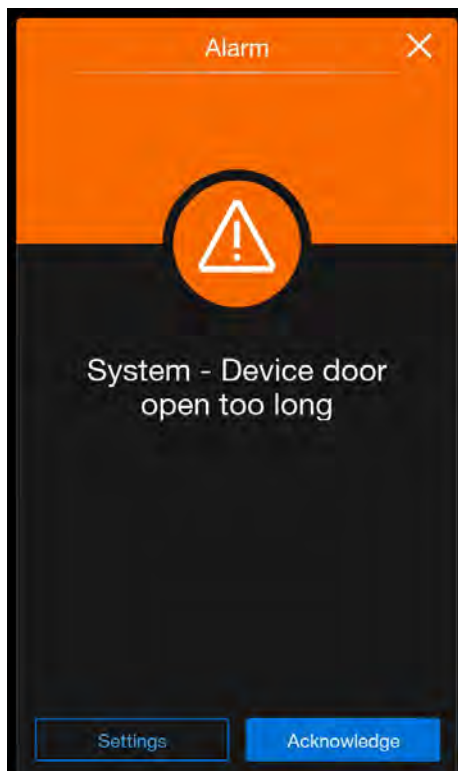

**Figure 6-38.** System error Door open too long

- the detected error is listed in the error table,
- the event is entered in the event display.

## Response to an error message event

If the alarm relay was switched due to a user action, the switching status can be reset by confirming the error message (e.g. for the manual cancellation of the Steri-Run sterilization cycle).

If the alarm relay was switched due to a technical error, the switching status remains active until the error has been corrected (e.g. water level in workspace too low).



**Figure 6-39.** Example of temperature error message

1. Click on the temperature display field.  
The "Temp Alarm" screen appears.



**Figure 6-40.** Temp alarm screen

2. Acknowledge the error by pressing the “Acknowledge” key.  
The screen returns to the start screen.

## Resetting overtemperature protection



### CAUTION

If you do not restart the device after an overtemperature error, damage to internal components may occur after a while.

When the device control has activated overtemperature protection and switched over to emergency control mode, a flashing warning triangle and the icon are displayed in the main menu.

1. Press anywhere on the touchscreen to display the cause of the error.  
The Error dialog box appears and the detected cause of the error lights up.  
The acoustic signal is switched off.
2. Press the “Accept” key to close the error display.  
The error message fades out.  
The temperature display field is outlined in red.
3. Switch off the device to clear the error message.
4. Open the doors and allow the workspace to cool.
5. Switch the device on.

Take the device out of service and call the technical service if the overtemperature protection is activated again despite the elimination of the possible causes of the error (see error table).

## Action after power failure

After a power failure, condensation of the moisture in the internal space can form on the sensors. This can impair their function to such an extent that incorrect measured values are displayed or the device even reports a defect (sensor breakage; see ["Overview of causes of errors and troubleshooting"](#) on [Page 6-51](#)).

The following action must be taken to ensure error-free operation:

1. Drain the water and allow the internal space to dry.
2. Without water, allow the instrument to heat up to 55°C (131 °F) for 1 hour.
3. Then allow the device to cool down with the doors open.
4. Then operate the device at incubation temperature as described in the chapter ["Start-up"](#) on [Page 4-1](#).

**Handling**

## Action after power failure

Alternatively, or if the action described above does not have the desired result, a sterilization run can be started at 180°C (356 °F). For this, see section "[Steri-Run sterilization cycle](#)" on [Page 8-5](#).

The sterilization process can be terminated after approximately 1 hour. The sensors should have dried by then.

## Overview of causes of errors and troubleshooting

The error tables provide information on source of error, cause of error, and possible troubleshooting measures.

When communicating with the Thermo Fisher Scientific Technical Service team, please have the device data ready.

System control loop					
Error message	Cause	Remedy	Alarm relay	Buzzer	Log
Device door open too long	Device door is for more than 10 min	Close device door	X	X	X
Error: Display	Display not communicating with the main board *1)	Reset device. If the error occurs repeatedly, call Service	X	X	X
Error: EEPROM main board	EEPROM on main board is defective	Reset device. If the error occurs repeatedly, call Service	X	X	X
Error: Data logger	Error writing to the data logger memory. Incubator remains functional.	Reset device. If the error occurs repeatedly, call Service			
Error: Steri-Run	Error in Steri-Run routine	Reset device. If the error occurs repeatedly, call Service	X	X	X
Power-down during Steri-Run	Power failure during Steri-Run routine	Restart device and re-launch Steri-Run.	X	X	X
Error: auto-start	Error in auto-start routine	Re-launch auto-start. If the error occurs repeatedly, call Service.	X	X	X
Error: ADC	Measurement of reference resistance out of tolerance	Reset device. If the error occurs repeatedly, call Service.	X	X	X
Error: Fan	Actual value of the fan is out of tolerance.	Reset device. If the error occurs repeatedly, call Service.	X	X	X

Temperature control loop					
Error message	Cause	Remedy	Alarm relay	Buzzer	Log
Sensor breakage	Measured value outside the accepted limit	Call Service. Conduct drying process.	X	X	X

## Handling

Action after power failure

Temperature control loop					
Error message	Cause	Remedy	Alarm relay	Buzzer	Log
Actual value high	Actual value > Set value + 1°C (33.8 °F) *2) *4)	Do not exceed permissible ambient temperature / Call Service.	X	X	X
Actual value low	Actual value < Set value + 1°C (33.8 °F)*3) *4)	If the error does not reset automatically, call Service.	X	X	X
Actual value not plausible	Implausible temperature signal	Reset device. If the error occurs repeatedly, call Service.	X	X	X
Calibration values too high/low	Max. calibration value for temperature exceeded/not attained	Acknowledge alarm, enter different target value.			X

CO <sub>2</sub> control loop					
Error message	Cause	Remedy	Alarm relay	Buzzer	Log
Sensor breakage	Measured value outside the accepted limit	Run auto-start. If the error subsequently occurs again, resolve the error according to the section " <a href="#">Action after power failure</a> " on <a href="#">Page 6-49</a> . If the error persists, call Service.	X	X	X
Actual value high	Actual value > Set value + 1% *4)	automatic	X	X	X
Actual value low	Actual value < Set value - 1% *3) *4)	automatic	X	X	X
RH Error communication	RH sensor not communicating with the main board	automatic	X	X	X

Temperature control loop					
Error message	Cause	Remedy	Alarm relay	Buzzer	Log
Actual value high	Actual value > Set value + 1°C (33.8 °F) *2) *4)	Do not exceed permissible ambient temperature / Call Service.	X	X	X
Actual value low	Actual value < Set value + 1°C (33.8 °F)*3) *4)	If the error does not reset automatically, call Service.	X	X	X
Actual value not plausible	Implausible temperature signal	Reset device. If the error occurs repeatedly, call Service.	X	X	X
Calibration values too high/low	Max. calibration value for temperature exceeded/not attained	Acknowledge alarm, enter different target value.			X

CO <sub>2</sub> control loop					
Error message	Cause	Remedy	Alarm relay	Buzzer	Log
Sensor breakage	Measured value outside the accepted limit	Run auto-start. If the error subsequently occurs again, resolve the error according to the section " <a href="#">Action after power failure</a> " on <a href="#">Page 6-49</a> . If the error persists, call Service.	X	X	X
Actual value high	Actual value > Set value + 1% *4)	automatic	X	X	X
Actual value low	Actual value < Set value - 1% *3) *4)	automatic	X	X	X
RH Error communication	RH sensor not communicating with the main board	automatic	X	X	X

**Handling**

Action after power failure

CO <sub>2</sub> control loop					
Error message	Cause	Remedy	Alarm relay	Buzzer	Log
Calibration values too high/low	Max. calibration value for CO <sub>2</sub> exceeded/not reached	Acknowledge alarm			X
Error communication	Sensor not communicating with the main board	automatic	X	X	X
No gas	The gas cylinder is empty or the gas supply is interrupted, or there is a malfunction	Replace at least one CO <sub>2</sub> cylinder.	X	X	X
RH sensor breakage	Measured value outside the accepted limit	Call Service. See also the section <a href="#">"Action after power failure"</a> on <a href="#">Page 6-49</a> .	X	X	X

O <sub>2</sub> control loop					
Error message	Cause	Remedy	Alarm relay	Buzzer	Log
Sensor breakage	Measured value outside the accepted limit	Call Service	X	X	X
Actual value high	Actual value > Set value + 1% *4)	Check gas supply. Lower pre-pressure to max. 1 bar.	X	X	X

O <sub>2</sub> control loop					
Error message	Cause	Remedy	Alarm relay	Buzzer	Log
Actual value low	Actual value < Set value - 1% *4)	Check gas supply. Replace gas cylinder. Raise pre-pressure to max. 1 bar. Check feed pipe.	X	X	X
Error communication	Sensor not communicating with the main board	Call Service	X	X	X
No gas	The gas cylinder is empty or the gas supply is interrupted, or there is a malfunction.	Replace at least one O <sub>2</sub> cylinder.	X	X	X

## Handling

Action after power failure

RH control loop					
Error message	Cause	Remedy	Alarm relay	Buzzer	Log
No water	Not enough water in water reservoir.	Add water or select the "Dry Incubation" function. The water level sensor is automatically deactivated. If the error message recurs in spite of top-up, perform troubleshooting as per the chapter <a href="#">"Action after power failure"</a> on <a href="#">Page 6-49</a> . If the error persists, call Service.	X	X	X

\*1) This error appears on the display only and is not entered in the error table.

\*2) If this error occurs, a special control mode is activated to protect the cultures. An icon appears to indicate this mode.

\*3) Waiting times before error message:

### **Overtemperature**

- 1 min after door opening
- 1 min after set value change

### **Low temperature**

- 45 min after door opening
- 300 min after set value change

### **CO<sub>2</sub> too high/low**

- 45 min after door opening
- 159 min after set value change

**O2 too high/low**

- 159 min after door opening
- 159 min after set value change

\*4) This value can be changed by Service.

# Shutdown

## Contents

- "Shutting the device down" on Page 7-1

## Shutting the device down



### WARNING

Contamination hazard!

The surfaces of the workspace may be contaminated. There is a risk that germs could remain inside the chamber.

Decontaminate the device before shutting down!

1. Remove the culture containers with the cultures and all accessories from the workspace.
2. Provide a collection vessel with sufficient capacity.
3. Place the end of the tube in the collection vessel and securely engage the tube valve.

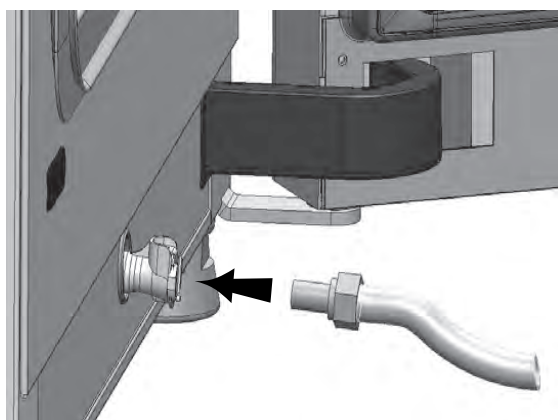

**Figure 7-1.** Fill and drain valve of the water reservoir

4. Completely empty the water reservoir into the collection vessel.

## Shutdown

Shutting the device down

5. Remove the tube valve again.
6. Start the Steri-Run sterilization cycle ("[Activate Steri-Run](#)" on [Page 8-10](#)).
7. Use the power switch to switch off the device when the Steri-Run sterilization cycle is complete.
8. Disconnect the mains plug and secure it against reconnection.
9. Close the closing valves of the CO<sub>2</sub>/O<sub>2</sub>/N<sub>2</sub> supply system.
10. Disconnect the gas pressure tubes from the connection valve on the back of the device.
11. Open the glass door and the outer door slightly and secure them in the open position so that the workspace is continuously ventilated during the shutdown phase.

# Cleaning and disinfection

## Contents

- "Cleaning" on Page 8-1
- "Decontamination procedures" on Page 8-2

## Cleaning

### CAUTION

Incompatible cleaning agents!

Some device components are made of plastic. Solvents can dissolve plastics. Strong acids or caustic solutions can cause plastics to become brittle.

- Do not use solvents that contain hydrocarbons, agents with an alcohol content of more than 10%, or strong acids or alkalis for cleaning plastic components and surfaces!

Moisture-sensitive components!

- Do not spray cleaning agent onto the display or the control box at the rear of the device.
- When wiping, be careful to prevent moisture from entering these components.



### Cleaning exterior surfaces:

1. Remove dirt residues and deposits thoroughly using a solution of lukewarm water and commercially available dishwashing agent.
2. Wipe the surfaces clean using a clean cloth and clear water.
3. Finally, rub the surfaces dry with a clean cloth.

## Cleaning the display:



### CAUTION

Moisture-sensitive display!

- Do not wipe the display with a damp cloth or spray it with cleaning agents!
- Dry the display with a cloth made of 100% microfiber!

## Decontamination procedures

Information on cleaning and disinfecting the Cell Locker is provided in the separate Cell Locker operating instructions (see [Appendix](#)).

To decontaminate the device, the operator must provide hygiene guidelines that coordinate the decontamination measures with the use of the device.

Wipe/spray disinfection and the Steri-Run sterilization cycle are suitable for the device.

## Recommended disinfectants

Type	Concentration	Product (example)
Ethanol	70%	Any
Isopropanol	70%	Any
Quaternary ammonium	10% or less (optimal 2%)	Conflikt™, Lysol™, No Rinse™, Fermacidal D2™
Hydrogen peroxide	1-3%	Any
Hydrogen peroxide/peracetic acid/acetic acid	1%/0.8%/<10%	Spor-Klenz Ready-to-Use (RTU); Sterilant (Steris Life sciences)

## Wipe/spray disinfection

Wipe/spray disinfection is used as the standard manual disinfection procedure for the device and for all accessories. It is carried out in three phases:

- Pre-disinfection
- Cleaning

- Final disinfection

### WARNING

Alcoholic disinfectants!

Disinfectants with an alcohol content of more than 10% may form, in combination with air, readily inflammable and explosive gas mixtures.

- When using such disinfectants, avoid open flames or exposure to strong heat during the entire disinfection process!
- Use disinfectants only in well-ventilated rooms.
- After exposure to the disinfectant, wipe the cleaned device components thoroughly dry.
- Observe the safety rules for avoiding fire and explosion hazards caused by disinfectants containing alcohol.



### WARNING

Chloride-containing disinfectants!

- Do not use disinfectants that contain chloride!



### DANGER

Electric shock!

Contact with current-carrying components may cause a lethal electric shock.

- Disconnect the device from the power supply before beginning manual cleaning and disinfection.
  - Switch off the device at the power switch.
  - Pull out the mains plug and secure it against accidental reconnection.
  - Make sure the device is de-energized.



### WARNING

Health hazard!

The surfaces of the workspace may be contaminated. Contact with contaminated cleaning liquids may cause infections. Disinfectants may contain substances that are harmful to health.

- Comply with the safety measures and hygiene rules during cleaning and disinfection!
  - Wear safety gloves.
  - Wear safety goggles.
  - Wear mouth and nose protection to protect your mucous membranes.
  - Observe the safety instructions of the disinfectant manufacturer and the hygiene supervisor.



## Pre-disinfection



### CAUTION

Moisture-sensitive components!

- Do not spray the CO<sub>2</sub> sensor and the O<sub>2</sub>/N<sub>2</sub> sensor behind the air duct with disinfectant.

1. Apply disinfectant to the surfaces of the workspace and fixtures and wipe them down.
2. Allow the disinfectant to work in according to the manufacturer's instructions and let air dry. This will remove chemical residues that could otherwise collect over time and cause damage to the incubator components.

## Remove components

1. Remove the insert shelves and then remove the entire shelf system from the workspace. Installation and removal of the shelf system are described in the section "[Installing the shelf system](#)" on [Page 4-7](#).
2. Remove the airbox and HEPA filter. Installation and removal of the airbox and HEPA filter are described in the section "[Replacing the HEPA filter](#)" on [Page 9-10](#).

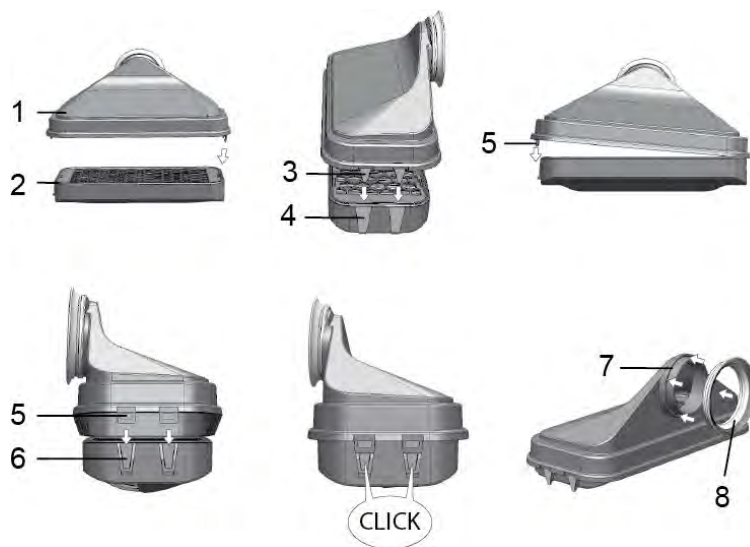

**Figure 8-1.** HEPA filter and airbox

3. Pull the upper part of the air duct ([Figure 8-1](#), 1) towards the front of the device and lift it down when the keyhole profiles on the front tabs release the holding pins in the workspace ceiling.
4. Unhook the top section from the back section of the air duct ([Figure 8-2](#), 2) and remove it from the work space.

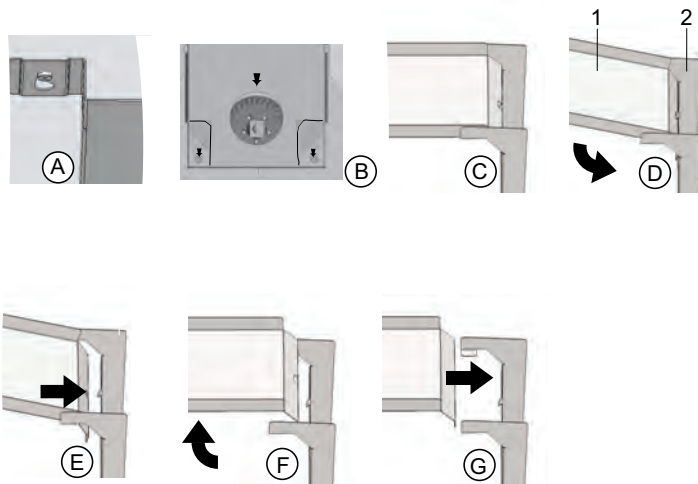

**Figure 8-2.** Air duct

5. Unhook the back part of the air duct (Figure 8-2, 2) from the rear panel and remove it.
6. Remove the pre-filter (Figure 3-1, 9).  
The pre-filter can be <sup>1</sup>autoclaved.
7. Remove the water reservoir cover.

### Cleaning the workspace and removed parts

1. Remove dirt residues and deposits thoroughly using a solution of lukewarm water and commercially available dishwashing agent.
2. Wipe the surfaces clean using a clean cloth with plenty of clear water.
3. Then remove the cleaning water from the water reservoir and rub all surfaces of the workspace thoroughly dry.
4. Clean the removed parts and wipe them dry as well.

### Final disinfection

1. Wipe the surfaces of the workspace, the shelf system, and the removed parts again with disinfectant or spray them with it.
2. Allow the disinfectant to work in according to the manufacturer's instructions.
3. Reassemble the shelf system and detachable parts.

### Steri-Run sterilization cycle

The Steri-Run sterilization cycle uses an automated program cycle to sterilize the complete workspace including the shelf system and the sensors.

Steri-Run is an automated sterilization cycle that works with a fixed nominal temperature (180°C (356 °F)) and a software-controlled routine for heating up, holding the nominal temperature, and cooling down.

<sup>1</sup> At 121°C (249.8 °F), 15 minutes, rapid pressure release

The entire program cycle of the sterilization routine takes under 12 hours. During this routine, a hot atmosphere at 180°C (356 °F) with a demonstrated 12-log sterility assurance level is created in the workspace for 90 minutes. The effectiveness of the Steri-Run sterilization cycle has been certified by independent institutes. The germ reduction achieved is equal to  $10^{12}$  (12-log reduction) as per the ISO 11138 standard. On request, Thermo Scientific will supply information on the pertinent tests.

The electromechanical door lock provides the Steri-Run sterilization cycle with additional protection against burns. It locks the outer door when the workspace temperature reaches 65°C (149 °F), then keeps it locked as long as hazardous temperatures prevail, and finally releases the door lock when the workspace temperature drops back below 65°C (149 °F).

## Preparing for disinfection or Steri-Run

1. Remove all cultures from the culture chamber and store them safely.
2. Provide a collection vessel with sufficient capacity.
3. Place the end of the tube in the collection vessel and securely engage the tube valve.

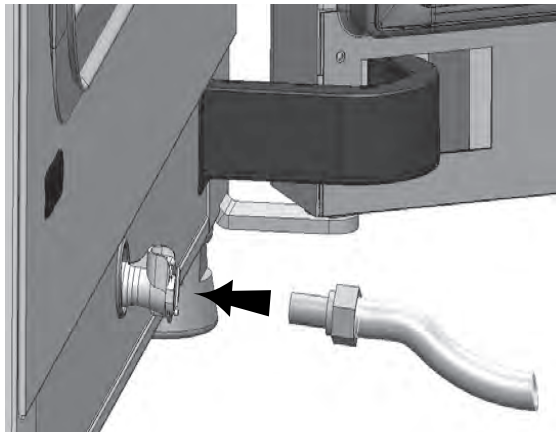

**Figure 8-3.** Fill and drain valve of the water reservoir

4. Completely empty the water reservoir into the collection vessel.
5. Wipe away the residual water with a cloth.
6. Pull the airbox (Figure 8-1, 1) from the base of the water reservoir cover and remove it.
7. Remove the HEPA filter (Figure 8-1, 2) from the airbox (Figure 8-1, 1) and install the airbox again.

## Perform disinfection or Steri-Run (cycle)

### WARNING

Hot surfaces!



The handle of the glass door, the inner panel of the outer door, and the surfaces of the shelf system and of the workspace become extremely hot during the Steri-Run sterilization cycle.

- During the cycle or immediately after completion of the cycle, always wear safety gloves when touching these surfaces!  
Incubators equipped with the door lock kit prevent access to the workspace while the interior surfaces are hot due to the Steri-Run sterilization cycle.

### CAUTION Damage to the cultures!

During the Steri-Run sterilization cycle, the workspace is heated to 180°C (356 °F).

- Ensure that:
  - all cultures have been removed from the workspace,
  - all accessories have been removed from the workspace,
  - the HEPA filter and all Cell Lockers have been removed from the workspace.



### CAUTION

Operating temperature limits for the Cell Locker!

- Remove the Cell Lockers prior to performing a Steri-Run sterilization cycle.

The maximum operating temperature for Cell Lockers is 121°C/250°F.

Cell Lockers melt in the incubator if exposed to the Steri-Run cycle.

Cell Lockers can be sterilized in an autoclave at 121°C (250 °F) for 15 minutes with rapid depressurization.

Cell Locker membrane filters may not be sterilized in an autoclave.



### **Note**

Prevention of the start of the Steri-Run sterilization cycle

The Steri-run sterilization cycle cannot be started if any of the following faults is detected:

#### **Temperature control loop**

- Sensor breakage
- Outer and/or inner door (if the outer door is open, the "Door open" error message appears)
- Actual value high (excessive deviation from set value)
- Actual value low (excessive deviation from set value)
- Actual value not plausible
- Error communication
- Water detected

#### **Overtemperature protection**

If the overtemperature protection has been activated on the device, the Steri-Run sterilization cycle cannot be started until the fault has been corrected or reset.

### **Note**

Once the cycle has been completed, the device must be restarted by launching the auto-start routine

1. After cleaning, reinstall the shelf system components in the workspace.
2. Switch on the device using the power switch.
3. Activate and start the Steri-Run sterilization cycle.
4. Switch off the device after the Steri-Run sterilization cycle is completed.
5. Remove the airbox (Figure 8-1, 1) and reinstall the HEPA filter (Figure 8-1, 2).
6. Resume operation with auto-start as needed.

## Operating phases of the Steri-Run sterilization cycle

The remaining run time of the Steri-Run sterilization cycle describes the time between the start or the current time status of the routine to the end of the "Cool-down" phase. The displayed remaining run times are not measured values but merely a guide.

The cycle is divided into three phases:

1. Heating phase,
2. Sterilization phase,
3. Cool-down.

### Heating phase

Approx. 2 h

The workspace is heated to 180°C (356 °F).  
Incubators equipped with the electromagnetic door lock kit lock the door when the workspace temperature exceeds 65°C (149 °F).

### Sterilization phase

Approx. 1.5 h

After the sterilization temperature has been generated, the sterilization phase is started and takes approximately 90 minutes. The temperature is maintained at 180°C (356 °F).

### Cool-down phase

Approx. 8 h

The device cools down until the original temperature set value is reached.  
Incubators equipped with the electromagnetic door lock kit release the door lock when the workspace temperature drops below 65°C (149 °F).

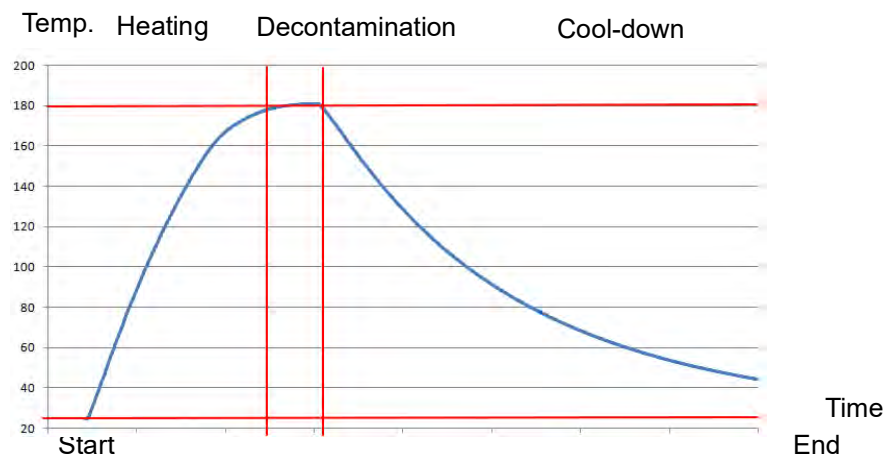
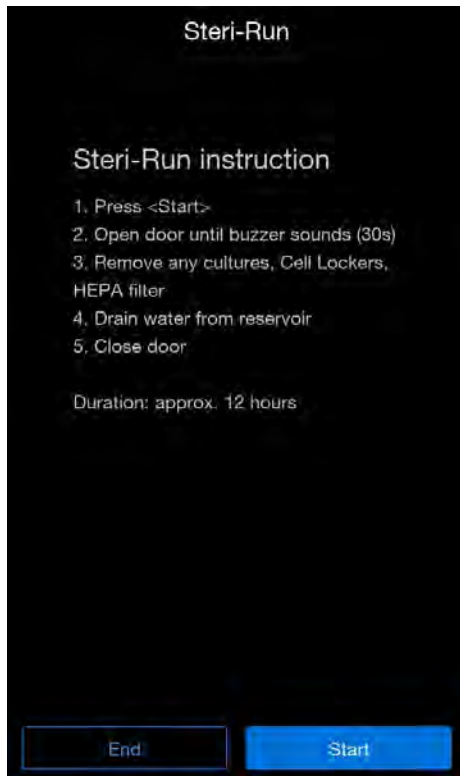

**Figure 8-4.** Phases of the Steri-Run sterilization cycle

## Activate Steri-Run

1. On the display start screen, press the "Steri-Run" key.

The Steri-Run menu is displayed:



**Figure 8-5.** Steri-Run menu

2. Press the "Start" key.
3. Ventilate the work space by opening both device doors until the time signal sounds, after 30 seconds.
4. Remove all cultures from the workspace.
5. Drain the water out of the water reservoir and wipe up any residual water.
6. After the time signal sounds, close both device doors.
7. Start Steri-Run.

The Steri-Run sterilization cycle begins. The device heats up, and the electromechanical door lock engages at 65°C (149 °F).

While the Steri-Run sterilization cycle is running, the display shows the current status and additionally issues the following information:

- Temperature
- Start time
- Phase

- Remaining run time

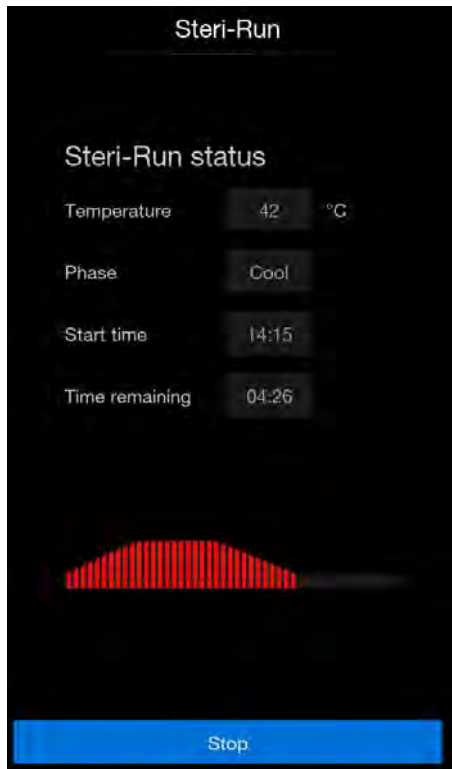

Figure 8-6. Steri-Run cycle

## Canceling Steri-Run

The Steri-Run sterilization cycle can be stopped at any time:

1. Press the “Stop” key.

The “Steri-Run Stop” dialog window appears as a security prompt. The routine can now be permanently canceled or resumed.

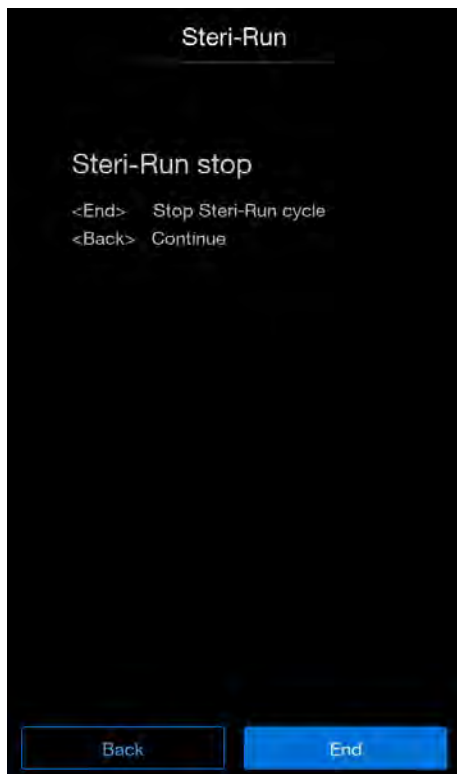

**Figure 8-7.** Steri-Run cancellation

### **Ending Steri-Run**

1. Press the "End" key.  
The system returns to the main menu.

### **Resuming Steri-Run**

1. Press the "Back" key.  
You will be returned to the status display, and the Steri-Run sterilization cycle will be continued.

### **Interrupting Steri-Run from the status display**

1. Press the "Stop" key.  
The "Steri-Run Stop" dialog window appears as a security prompt. Proceed as described under "Ending Steri-Run."

## Steri-Run interruption due to error

If an error occurs while the sterilization cycle is running, an error message is issued and the following action is initiated:

- The Steri-Run sterilization cycle automatically changes to the cooling phase.
  - The acoustic signal (buzzer) sounds.
1. Confirm the acoustic signal by touching the display in any place.

The acoustic signal stops. The "End" key is displayed. If the Steri-Run sterilization cycle is not then manually canceled, the workspace is cooled to the set temperature and dried.

## Completing Steri-Run

After all three phases have been completed, the "Steri-Run End" dialog window (Figure 8-8) is automatically displayed. The Steri-Run sterilization cycle must be ended manually.

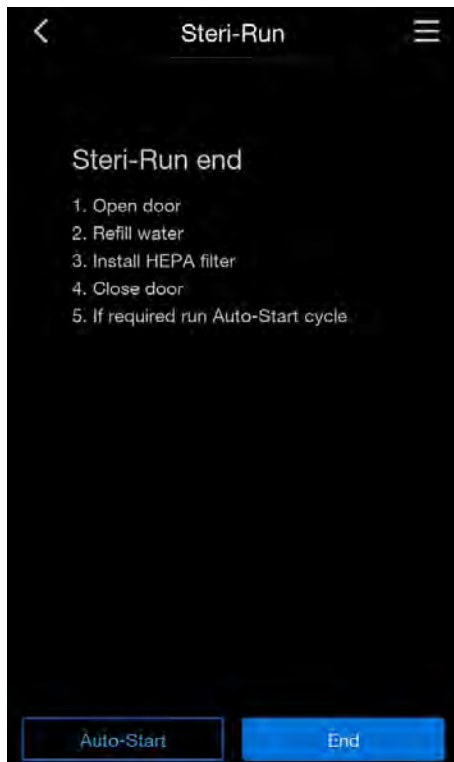

**Figure 8-8.** Ending Steri-Run

- Press the "End" key.  
The system returns to the main menu.

## Opening the door after canceling the Steri-Run sterilization cycle

### WARNING

Hot surfaces!



The handle of the glass door, the inner panel of the outer door, and the surfaces of the shelf system and of the workspace become extremely hot during the Steri-Run sterilization cycle.

During the cycle or immediately after cancellation of the routine, always wear safety gloves when touching these surfaces!

On devices with the electromechanical door lock kit, the door cannot be opened immediately after cancellation of the Steri-Run sterilization cycle by the user or due to a fault.

To release the outer door lock before the temperature has dropped to a non-hazardous level of 65°C (149 °F), you must actuate the emergency release lever (Figure 8-9, 1):

1. Determine the position of the emergency release lever (Figure 8-9, 1) on the underside of the incubator. It is located on the left side of the device, approximately 5 cm from/behind the power switch (Figure 8-9, 2).

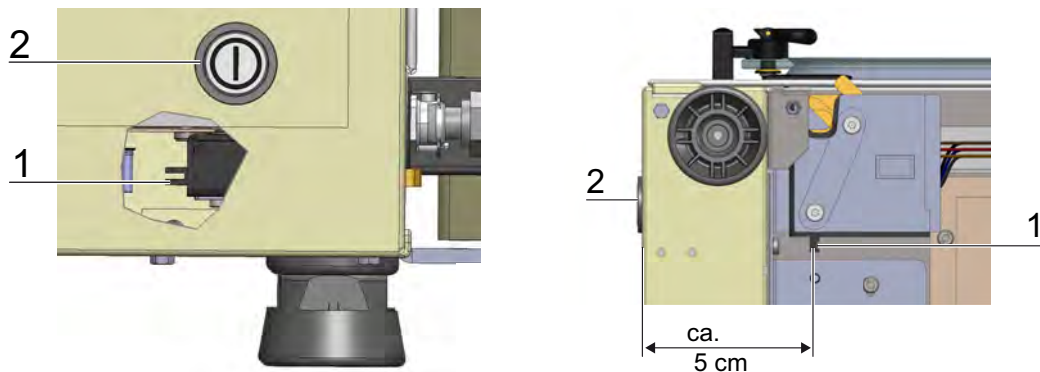

**Figure 8-9.** Emergency release on the underside of the incubator

2. Reach under the base panel and pull the emergency release lever (Figure 8-9, 1).  
The door lock disengages, and the outer door can be opened.

# Maintenance

## Contents

- "Inspections and checks" on Page 9-1
- "Maintenance intervals" on Page 9-2
- "Temperature calibration" on Page 9-3
- "CO<sub>2</sub> calibration" on Page 9-7
- "Replacing the HEPA filter" on Page 9-10
- "Replacing the gas intake filter" on Page 9-12
- "Replacing the device fuses" on Page 9-13
- "Replacing the door seal" on Page 9-13

## Inspections and checks

### WARNING

#### Function test

If safety devices were removed or disabled for inspections, the device must not be operated until the safety devices have been reinstalled and checked for their correct function.

To maintain the functionality and safety of the device, the functions and device components listed below must be tested at regular intervals.

Information on Cell Locker maintenance can be found in the separate Cell Locker operating instructions (see [Appendix](#)).

### Daily check

- Gas reserve of the CO<sub>2</sub> supply system
- Gas reserve of the O<sub>2</sub>/N<sub>2</sub> supply system

## Annual inspection

- Tightness of the glass door seal
- Permeability of the pressure compensation opening with filter
- Function test of the control panel and the device control
- Electrical safety check in accordance with the current national regulations (e.g. BGV 3)

## Maintenance intervals

- Perform the following maintenance work during operation:

### Monthly maintenance

- Manually clean and disinfect the device.
- Drain the sterilized distilled water and replace it with fresh sterilized distilled water.

### Quarterly maintenance

- Run the Steri-Run sterilization cycle and auto-start routine.
- Perform temperature and CO<sub>2</sub>/O<sub>2</sub> comparison measurement.

### Semi-annual maintenance

#### Note

Information on Cell Locker seals and membrane filters can be found in the corresponding operating instructions (see [Appendix](#)).

- Every 6 months, inspect each door seal and replace as necessary.

### Annual maintenance

#### Note

Maintenance contract

Thermo Scientific offer a device-specific maintenance contact that includes all necessary inspection and maintenance services.

- Change the gas intake filter.
- Change the HEPA filter
- Have a service check carried out by the Technical Service.

# Temperature calibration

## Preparing the temperature calibration

A temperature calibration measurement should be carried out on a quarterly basis to determine the exact measured value of the device-internal temperature sensor. If a major measurement deviation is determined, perform a temperature calibration:

- Set the temperature control of the device to the measured value of the comparison measurement. For the comparison measurement, use a calibrated measuring instrument with an accuracy of  $< \pm 0.1^{\circ}\text{C}$  ( $33.8^{\circ}\text{F}$ ). The reference site of the comparison measurement is the middle of the workspace.

### Note

Workspace temperature too high:

A possibly excessive workspace temperature after calibration can be remedied by opening the doors for approximately 30 seconds.

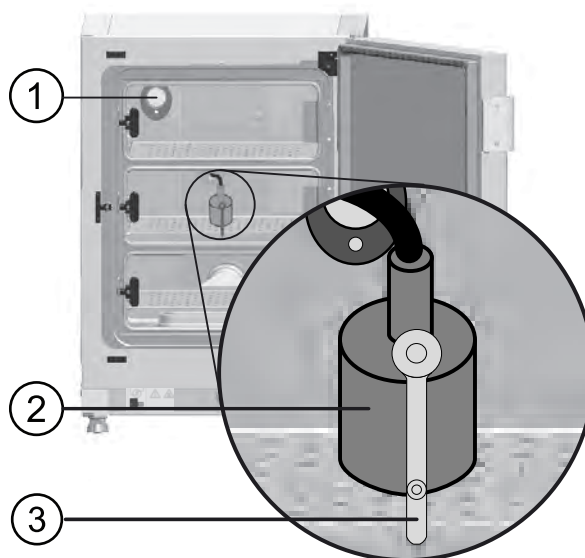

Figure 9-1. Preparing the temperature calibration

## **Conducting the comparison measurement**

1. Switch on the device at the power switch.
2. Adjust the temperature set value and wait until the device has warmed up. This may take several hours.
3. Place the measuring instrument (2) in the middle of the shelf in the middle area of the workspace or, alternatively, position a temperature sensor in the same place.
4. Route the supply line either through the measurement opening in the glass door (3) or through the access port (1) on the back of the device.
5. Close the doors.
6. Wait until a constant temperature value can be read on the measuring instrument.
7. Perform the temperature calibration.

## Performing the temperature calibration

Measurement example:

Target set value: 37°C (98.6 °F)

Measured comparison temperature: 36°C (96.8 °F)

1. Press the temperature display field on the start screen.

The temperature menu ([Figure 9-2](#)) is displayed.



**Figure 9-2.** Temperature selection menu

2. Leave the temperature menu by pressing the “Done” key.
3. Call up the Calibration sub-menu:
  - a. Press the “Menu” key on the start screen.
  - b. Select the “Settings/setup” menu command.
  - c. Select the “Calibration” menu command.
  - d. Select the “Temperature” menu command.

The “Temperature calibration” menu will open:



**Figure 9-3.** Performing the temperature calibration

4. Enter the measured value (target value).

**Note**

The target value may be increased or decreased in increments. Pressing and holding the respective - or + keys switches the function to fast forward. After approximately three seconds, the speed of the fast forward is additionally increased.

5. Press the "Done" key to apply and save the target value.
6. Press the "Cancel" key to abort the procedure.

You will be returned to the "Calibration" menu. The temperature display shows the actual value currently measured in the workspace.

**Note**

Workspace temperature too high

A possibly excessive workspace temperature after calibration can be remedied by opening the doors for approximately 30 seconds.

If the value has not changed within 30 seconds, the system automatically exits the menu, and the most recently confirmed value is applied.

# CO<sub>2</sub> calibration

## Preparing CO<sub>2</sub> calibration

A CO<sub>2</sub> comparison measurement should be carried out quarterly to determine the exact measured value of the device-internal CO<sub>2</sub> sensor. If you notice a major measurement deviation, perform a CO<sub>2</sub> calibration:

- Set the CO<sub>2</sub> control of the device to the measured value of the comparison measurement. For the comparison measurement, use a calibrated measuring instrument (hand-held IR measuring device) with an accuracy of  $< \pm 0.3\%$  CO<sub>2</sub>.
- Remove the measurement culture through the closable measurement opening [1] of the glass door. Perform the comparison measurement on the warmed-up device.

## Conducting the comparison measurement

1. Switch on the device at the power switch.
2. Set the CO<sub>2</sub> set value and wait until the appliance has warmed through and the humidity has built up.
3. Guide the measuring probe of the hand-held IR measuring device through the measurement opening into the workspace. Wait until a constant CO<sub>2</sub> value can be read on the measuring device.

### Note

For devices equipped with the optional segmented inner door, the measurement opening is located:

- for Vios iDx 165 in the middle segment of the segmented inner door
- for Vios iDx 255 in the left or middle segment of the segmented inner door

4. Remove the measuring probe.
5. Close the measurement opening and the doors.
6. Calibrate the CO<sub>2</sub> control.

### Note

IR measuring cell

For devices with an IR measuring cell, the CO<sub>2</sub> calibration can only be carried out at a set CO<sub>2</sub> concentration of 4.0% CO<sub>2</sub> or higher.

Calibration should be performed at the CO<sub>2</sub> set value designated for the work process (prospective work process value).

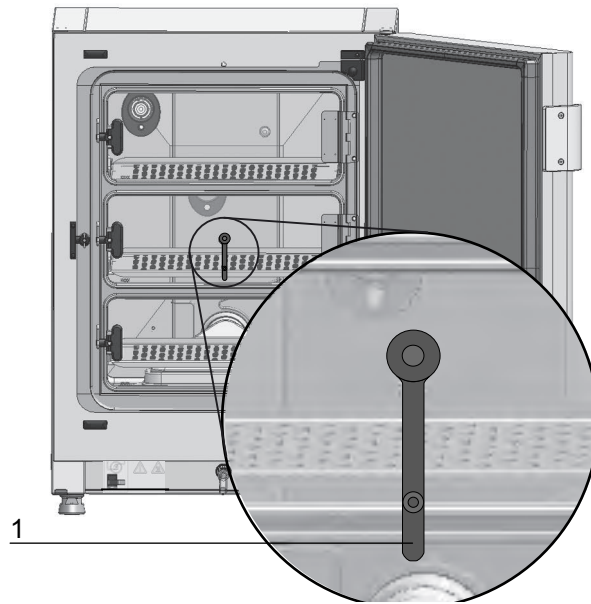

**Figure 9-4.** Measurement opening in a segmented inner door

## Performing CO<sub>2</sub> calibration

Measurement example:

CO<sub>2</sub> set value: 5%

Reference value: 6%

1. Press the CO<sub>2</sub> display field on the start screen.  
The CO<sub>2</sub> menu is displayed.

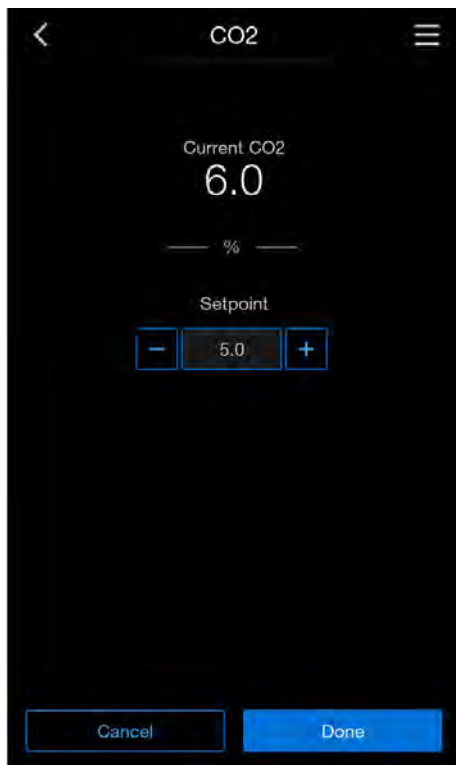

**Figure 9-5.** CO<sub>2</sub> selection menu

2. Press the “Done” key to leave the CO<sub>2</sub> menu
3. Call up the Calibration sub-menu:
  - a. Press the “Menu” key on the start screen.
  - b. Select the “Settings/setup” menu command.
  - c. Select the “Calibration” menu command.
  - d. Select the “CO<sub>2</sub>” menu command.

The “CO<sub>2</sub> calibration” menu opens:

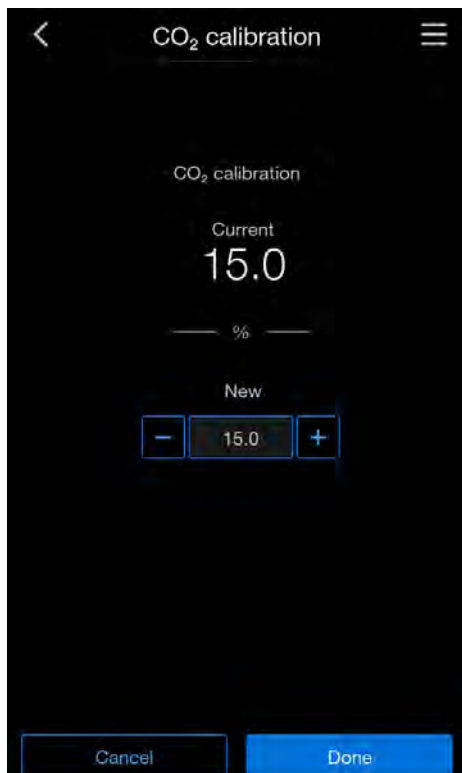

**Figure 9-6.** Performing CO<sub>2</sub> calibration

4. Enter the measured value (target value).

**Note**

The target value may be increased or decreased in increments. Pressing and holding the respective - or + keys switches the function to fast forward. After approximately three seconds, the speed of the fast forward is additionally increased.

5. Press the “Done” key to apply and save the target value.
6. You will be returned to the “Calibration” menu. The CO<sub>2</sub> display field shows the actual value currently measured in the workspace.

**Note**

Excessive CO<sub>2</sub> content

A possibly excessive CO<sub>2</sub> level after calibration can be remedied by opening the doors for approximately 30 seconds.

If the value has not changed within 30 seconds, the system automatically exits the menu, and the most recently confirmed value is applied.

## Replacing the HEPA filter

The HEPA filter is located under a plastic hood (airbox) on the floor in front of the rear wall of the workspace.

1. Switch off the device.

2. Turn off the gas supply.
3. Allow the gas to dissipate from the workspace.
4. Take the middle and lower shelves out of the workspace.
5. Lift the water reservoir cover at the front. (Figure 9-7, 1)

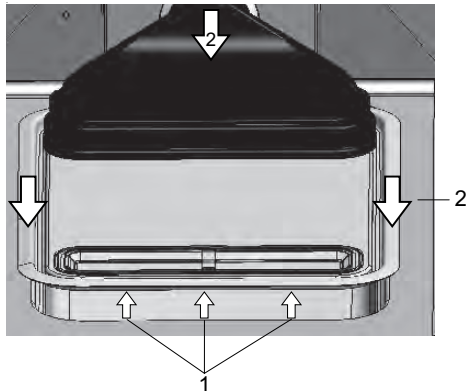

**Figure 9-7.** Removing the airbox

6. Pull the water reservoir cover forward and out. (Figure 9-7, 2).
7. Remove the airbox with the HEPA filter.
8. Turn the airbox over and unhook the tabs (Figure 9-8, 5) on the left side of the airbox from the catches (Figure 9-8, 6) of the HEPA filter.
9. Remove the tabs on the right side (Figure 9-8, 3) of the air box (Figure 9-8, 1) from the corresponding grooves in the HEPA filter (Figure 9-8, 4).

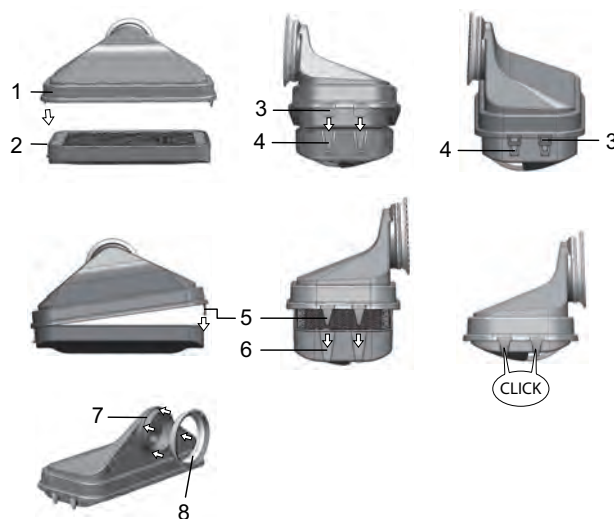

**Figure 9-8.** Installing the HEPA filter

10. Place the new HEPA filter in the airbox (Figure 9-8, 1) and lock it in place.
11. Place the airbox on the base of the water reservoir cover.
12. Activate the HEPA filter according to the instructions "HEPA configuration" on Page 6-19 in the user configuration if the device was previously operated without the HEPA filter.

## Maintenance

### Replacing the gas intake filter

13. If necessary, set the reminder interval for replacing the HEPA filter according to the instructions "Reminder intervals" on [Page 6-39](#) in the user configuration.

## Replacing the gas intake filter

The gas intake filter (CO<sub>2</sub>/O<sub>2</sub>/N<sub>2</sub>supply) has a plastic thread and is screwed by hand into the threaded socket at the control box.

### Gas intake filter of the gas supply

1. Make sure that the gas supply is shut off.
2. Release the hose clamp ([Figure 9-9, 4](#)).
3. Disconnect the gas hose ([Figure 9-9, 5](#)) from the connector of the gas intake filter.
4. Unscrew the locking plate ([Figure 9-9, 1](#)).
5. Unscrew the gas intake filter ([Figure 9-9, 2](#)) from the threaded socket ([Figure 9-9, 3](#)).
6. When screwing in the new gas intake filter, make sure that the plastic thread is not tilted. Carefully screw in the gas intake filter.
7. Screw on the locking plate.
8. Mount the gas hose on the connector of the filter and fasten it with the hose clamp. Check that the gas hose is tightly seated on the connector.

### All gas intake filters

1. Make sure that the gas supply is shut off.
2. Unscrew the locking plate ([Figure 9-9, 1](#)).
3. Unscrew the gas intake filter ([Figure 9-9, 2](#)) from the threaded socket ([Figure 9-9, 3](#)).
4. When screwing in the new gas inlet filter, make sure that the plastic thread is not tilted. Carefully screw in the gas intake filter.
5. Screw on the locking plate.

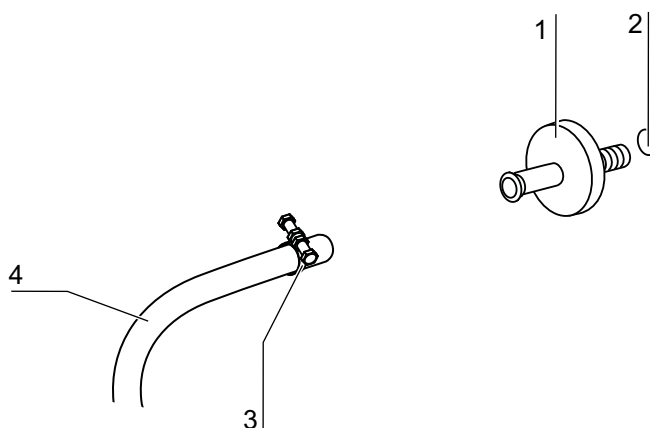

**Figure 9-9.** Gas intake filter installation

## Replacing the device fuses

The device fuses cannot be replaced by the user. If the device fails due to an electrical fault, call Technical Service.

## Replacing the door seal

### **Note**

We recommend having the door seal replaced by a service technician or by qualified specialist staff.

# Disposal

## Contents

- "Overview of the materials used" on Page 10-2



WEEE compliance:

This product has to comply with EC Directive 2012/19/EU on waste electrical and electronic equipment (WEEE). It is marked with the adjacent symbol.

## WARNING

Contamination hazard!



The device may have been used for treating and processing infectious substances. Therefore, the device and device components may have been contaminated. Prior to disposal, all device components must be decontaminated!

- Thoroughly clean the components of the device and then disinfect or sterilize them, depending on their intended use.
- Provide the goods for disposal with a declaration of harmlessness with precise information about the implementation of disinfection measures.

All components of the device can be sent for regulated disposal in accordance with the nationally applicable guidelines after appropriate decontamination.

HEPA filters must be disposed of in accordance with the applicable national directives on the handling of hazardous waste.

## Note

Recycling service:

Thermo Fisher Scientific offers an environmentally sound recycling service for used devices.

## Note

Before the device is disposed of, all stored personal data must be completely and irreversibly deleted in order to comply with international and national data protection laws and regulations.

## Overview of the materials used

Component	Material
Thermal insulation components	Glass wool, glass wool with single-sided glass mat lining
Printed circuit boards	Coated electrical components containing various plastics, mounted on circuit boards containing epoxy resin bonder.
Plastic parts, general	ABS and PPS GF40, note material identification
Outer housing	Galvanized and painted steel sheet, Stainless steel 1.4016
Incubator rear wall	Galvanized steel sheet
Outer door	Galvanized and painted steel sheet, Stainless steel 1.4016
Door inner panel	1.4301 stainless steel sheeting
Control panel and display film	Polyethylene
Heaters	Silicone-sheathed resistance heating wires
Workspace containers, installed components, and shelves	Electropolished stainless steel 1.4301, 100% natural copper
Insert for pressure compensation opening	Stainless steel 1.4301 (base), 1.4404 (sintered filter)
Glass pane	Sodium silicate glass
Sensor block (WLD)	Stainless steel 1.4301
Piping	Plastics- and silicon-sheathed copper stranded wire
Elastomers, general	Silicone
Filters	HEPA filter, micro-fine glass, Cell Locker: membrane filter with ABS and silicone Gas filter with polypropylene housing and GF/PTFE membrane, Pre-filter, stainless steel 1.4401 wire mesh
Packaging	Corrugated cardboard, polyethylene film styrofoam molded parts, and polypropylene
Door seal magnet	Permanent magnet
Cell Locker	Polycarbonate Makrolon 2528
Device feet	Polyamide

# Specifications

## Contents

- "Vios iDx 165" on Page 11-2
- "Vios iDx 255" on Page 11-6

## Vios iDx 165

Description	Unit	Value
<b>Mechanical</b>		
Outer dimensions (W x H x D)	mm / inch	637 x 900 x 880 (25.08 x 35.43 x 34.65)
Inner dimensions (W x H x D)	mm / inch	470 x 607 x 576 (18.50 x 23.89 x 22.68)
Inner space volume, of which usable volume	L L	approx. 165 approx. 100
Insert shelves (W x D)	mm / inch	423 x 465 (16.65 x 18.31)
Quantity, scope of delivery	pcs.	3
Quantity, maximum	pcs.	11
Surface loading capacity, maximum	kg / lbs	10 per insert shelf
Overall device loading capacity, maximum	kg / lbs	30 / 66.14
Weight	kg / lbs	82 / 180.78
<b>Thermal</b>		
Thermal safety features in accordance with DIN 12880:2007-05		Class 3.1 (Overtemperature controller, providing alarming function upon excessive temperature condition)
Ambient temperature range	°C / °F	+18...34 (+64.4...93.2)
Ambient temperature for stacked devices	°C / °F	+18...28 (+64.4...82.4)
Temperature control range, incubation		RT + 3...55
Temperature deviation, temporal (DIN 12880, part 2) at 37 °C (98.6 °F)		± 0.1
Temperature deviation, spatial (DIN 12880, part 2) at 37 °C (98.6 °F) <sup>a*</sup>		≤ ± 0.3
Duration of the auto-start routine: up to 37 °C (98.6 °F) Ambient temperature 20 °C (68 °F)	h	5...10
Heat transfer to environment:		
at 37 °C (98.6 °F)	kWh/h	0.06
During Steri-Run sterilization cycle	kWh/h	0.59

Description	Unit	Value
<b>Humidity</b>		
Sterile distilled water qualities		Resistivity: 50 KΩcm to 1 MΩcm Conductivity: 1 to 20 μS/cm
Fill quantities: Incubation operation	L	max. 3 / min 0.5
Constant humidity at 37 °C (98.6 °F) (high humidity mode)	% RH	approx. 93 <sup>b</sup>
Constant humidity at 37 °C (98.6 °F) (low humidity mode)	% RH	approx. 90
<b>Other</b>		
Noise level (DIN 45 635, part 1)	dB(A)	< 50
Relative ambient humidity	% RH	max. 80
Altitude of installation site	meters above sea level	max. 2000

<sup>a</sup>Values determined on the basis of DIN 12880 for standard devices. Consult the calibration instructions for further information.

<sup>b</sup>The specifications are met under standard laboratory conditions at sea level, at an ambient temperature of +22 °C (71.6 °F) and rated operating voltage. Other process conditions or ambient temperatures or altitudes may affect performance by up to ± 2.5%. For example, a 2 °C (35.6 °F) change in ambient temperature can affect relative humidity by 1% RH.

## Vios iDx 165

Description	Unit	Value
<b>CO<sub>2</sub> gas supply system</b>		
Gas purity	%	min. 99.5 or med. quality
Preset pressure	bar / psi	min. 0.8 - max. 1 (11.6 - 14.5)
Instrumentation and control range	vol -%	0...20
Control deviation, temporal	vol -%	± 0.1
<b>CO<sub>2</sub> measurement cell</b>		
Accuracy at 37°C (98.6 °F) and 5% CO <sub>2</sub>	%CO <sub>2</sub>	± 0.3
<b>O<sub>2</sub>/N<sub>2</sub> gas supply system</b>		
Gas purity	%	min. 99.5 or med. quality
Preset pressure	bar / psi	min. 0.8 - max. 1 (11.6 - 14.5)
Instrumentation and control range	vol -%	1... 21 or 5...90
Control deviation, temporal	vol -%	± 0.2
<b>O<sub>2</sub> measurement cell</b>		
Accuracy at 37°C (98.6 °F) and 21% O <sub>2</sub>	%O <sub>2</sub>	± 0.5 (Option: 1.....21% O <sub>2</sub> ) ± 2.0 (Option: 5.....90% O <sub>2</sub> )
<b>Electric</b>		
Rated voltage	V	1/N/PE 230 V, AC (± 10%) 1/N/PE 220 V, AC (± 10%) 1/N/PE 120 V, AC (± 10%) 1/N/PE 100 V, AC (± 10%)
Rated frequency	Hz	50/60
Degree of protection (IEC 60529)		IP 20
Protection class		I
Overvoltage category (EN 61010)		II
Degree of pollution (EN 61010)		2

Description	Unit	Value
Rated current	A	<b>230 V:</b> Sterilization: 4.6 Incubation: 2.4 <b>220 V:</b> Sterilization: 4.4 Incubation: 2.3 <b>120 V:</b> Sterilization: 8.3; Incubation: 4.6 <b>100 V:</b> Sterilization: 7.2; Incubation: 3.9
		Circuit breaker
Rated consumption	kW	<b>230 V:</b> Sterilization: 1.10 Incubation: 0.56 <b>220 V:</b> Sterilization: 0.97 Incubation: 0.51 <b>120 V:</b> Sterilization: 1.01 Incubation: 0.55 <b>100 V:</b> Sterilization: 0.72 Incubation: 0.39

## Vios iDx 255

Description	Unit	Value
<b>Mechanical</b>		
Outer dimensions (W x H x D)	mm / inch	774 x 969 x 934 (30.47 x 38.15 x 36.77)
Inner dimensions (W x H x D)	mm / inch	607 x 670 x 629 (23.90 x 26.38 x 24.76)
Inner space volume, of which usable volume	L	approx. 255
	L	approx. 162
Insert shelves (W x D)	mm / inch	560 x 500 (22.05 x 19.68)
Quantity, scope of delivery	pcs.	3
Quantity, maximum	pcs.	12
Surface loading capacity, maximum	kg / lbs	10 (22.05) per insert shelf (copper)
		14 (30.86) per insert shelf (stainless steel)
Overall device loading capacity, maximum	kg	30 insert shelf (copper)
		42 insert shelf (stainless steel)
Weight	kg / lbs	105 / 231
<b>Thermal</b>		
Thermal safety features in accordance with DIN 12880:2007-05		Class 3.1 (Overtemperature controller, providing alarming function upon excessive temperature condition)
Ambient temperature range	°C / °F	+18...34 (+64.4...93.2)
Ambient temperature for stacked devices	°C / °F	+18...28 (+64.4...82.4)
Temperature control range, incubation		RT + 3...55
Temperature deviation, temporal (DIN 12880, part 2) at 37°C (98.6 °F))		± 0.1
Temperature deviation, spatial (DIN 12880, part 2) at 37°C (98.6 °F) <sup>a</sup> )		± 0.3
Duration of the auto-start routine: up to 37°C (98.6 °F) Ambient temperature 20°C (68 kg)	h	5...10
Heat transfer to environment		
at 37°C (98.6 °F)	kWh/h	0.07
During Steri-Run sterilization cycle	kWh/h	0.75

Description	Unit	Value
<b>Humidity</b>		
Sterile distilled water qualities		Resistivity: 50 KΩ cm to 1 MΩ cm Conductivity: 1 to 20 μS/cm
Fill quantities: Incubation operation	L	max. 3 / min 0.5
Constant humidity at 37°C (98.6 °F) (high humidity mode)	% RH	approx. 93 <sup>b</sup>
Constant humidity at 37°C (98.6 °F) (low humidity mode)	% RH	approx. 90
<b>Other</b>		
Noise level (DIN 45 635, part 1)	dB(A)	< 50
Relative ambient humidity	% RH	max. 80
Altitude of installation site	meters above sea level	max. 2000

<sup>a</sup>Values determined on the basis of DIN 12880 for standard devices. Consult the calibration instructions for further information.

<sup>b</sup>The specifications are met under standard laboratory conditions at sea level, at an ambient temperature of +22°C and rated operating voltage. Other process conditions or ambient temperatures or altitudes may affect performance by up to ± 2.5%. For example, a 2°C change in ambient temperature can affect relative humidity by 1% RH.

## Vios iDx 255

Description	Unit	Value
<b>CO<sub>2</sub> gas technology</b>		
Gas purity	%	min. 99.5 or med. quality
Preset pressure	bar / psi	min. 0.8 - max. 1 (11.6 - 14.5)
Instrumentation and control range	vol -%	0...20
Control deviation, temporal	vol -%	± 0.1
<b>CO<sub>2</sub> measurement cell</b>		
Accuracy at 37°C (98.6 °F) and 5% CO <sub>2</sub>	%CO <sub>2</sub>	± 0.3
<b>O<sub>2</sub>/N<sub>2</sub> gas technology</b>		
Gas purity	%	min. 99.5 or med. quality
Preset pressure	bar	min. 0.8 - max. 1
Instrumentation and control range	vol -%	1... 21 or 5...90
Control deviation, temporal	vol -%	± 0.2
<b>O<sub>2</sub> measurement cell</b>		
Accuracy at 37°C (98.6 °F) and 21% O <sub>2</sub>	%O <sub>2</sub>	± 0.5 (Option: 1.....21% O <sub>2</sub> ) ± 2.0 (Option: 5.....90% O <sub>2</sub> )
<b>Electric</b>		
Rated voltage	V	1/N/PE 230 V, AC (± 10%) 1/N/PE 220 V, AC (± 10%) 1/N/PE 120 V, AC (± 10%) 1/N/PE 100 V, AC (± 10%)
Rated frequency	Hz	50/60
Degree of protection (IEC 60529)		IP 20
Protection class		I
Overvoltage category (EN 61010)		II
Degree of pollution (EN 61010)		2

Description	Unit	Value
Rated current	A	<b>230 V:</b> Sterilization: 5.5 Incubation: 3.3
		<b>220 V:</b> Sterilization: 5.3 Incubation: 3.2
		<b>120 V:</b> Sterilization: 10.4; Incubation: 6.3
		<b>100 V:</b> Sterilization: 8.9; Incubation: 5.3
Circuit breaker		16 A
Rated consumption	kW	<b>230 V:</b> Sterilization: 1.26 Incubation: 0.76
		<b>220 V:</b> Sterilization: 1.16 Incubation: 0.69
		<b>120 V:</b> Sterilization: 1.25 Incubation: 0.75
		<b>100 V:</b> Sterilization: 0.89 Incubation: 0.53

\*1) Values determined on the basis of DIN 12880 for standard devices. Consult the calibration instructions for further information.

# Data communication

## Contents

- "Structure of the command sequences for data communication" on Page 12-4
- "Overview of general parameters (Addresses 0xxx)" on Page 12-5
- "Overview of incubator parameters (Addresses 2xxx)" on Page 12-6
- "Error memory structure" on Page 12-8
- "Data logger structure" on Page 12-12
- "Examples of data logger codes" on Page 12-16
- "Vios iDx 165/255 program" on Page 12-22

## USB interface

The devices are equipped with a USB interface. The USB interface complies with Standard USB 1.1 / USB 2.0 / USB 3.0 (full speed). The USB port is operated as a virtual COM port. Data exchange is accomplished via a defined command sequence structure. The command sequences correspond to the structure diagram of the RS 232 interface.

### Note

Installing the USB port with the virtual COM port

- If the USB interface is to be used for data exchange between PC and incubator, the USB port is installed as a virtual COM port (USB serial port) using the driver supplied.
- Determine the assigned COM port in the Windows Device Manager/ports dialog window: e.g. USB Serial Port (COM5) and then define it in the Vios iDx 165/255 program as the communications interface (see "[Vios iDx 165/255 program](#)" on [Page 12-22](#)).



Figure 12-41. Device manager

The driver can be run with the following operating systems:  
Windows 7, Windows 8, Windows 2000, Windows XP, Windows Vista.

## Installing the USB interface driver

1. Connect the USB cable to the USB interface (optional) on the control box of the Vios iDx 165/255 and connect it to a PC.

As soon as the Windows Hardware Detector has identified the USB port, the FIND NEW HARDWARE wizard dialog window opens.

2. Select the option DO NOT SEARCH FOR SOFTWARE.



Figure 12-42. Installing the USB interface driver - 1

3. Select the option INSTALL SOFTWARE FROM A CERTAIN SOURCE.



**Figure 12-43.** Installing the USB interface driver - 2  
4. Select the data CD as the source.



**Figure 12-44.** Installing the USB interface driver - 3

## Data communication

Structure of the command sequences for data communication

5. On the data CD, select the subdirectory DRIVER.



**Figure 12-45.** Installing the USB interface driver - 4

The installation routine installs the driver: EVAL22 Board USB.

6. End the routine after a successful installation with FINISH.

## Structure of the command sequences for data communication

All characters sent and received in the data exchange between a PC and the Vios iDx 165/255 incubator are ASCII characters that can be displayed on a conventional terminal. This ensures that communication can be set up, controlled, and programmed easily.

### Description of the protocol

Character coding:

ASCII characters, capital letters are not allowed.

Reading parameters:

Query:           ?:aaaa:bb::cc<CR>

or:               ?:aaaa:bb:XXXX:cc<CR>

Response:       !:aaaa:bb:XXXXX:cc<CR>

with:            aaaa = parameter address

bb = quantity of payload in this telegram (00 – ff)

cc = checksum: CRC8-CCITT:  $x^8 + x^2 + x^1 + 1 = 0x07$

without cc and <CR>

XXXX = bb-bytes payload

Description of the response elements:

aaaa            parameter address

bb               quantity of payload in this telegram (00 – ff)

cc               checksum: inverted XOR of all bytes without  
checksum and <CR>

Example of a software version query (50111927):

Query:           ?:0001:00::cc<CR>  
Response:       !:0001:08:50111927:cc<CR>

Writing parameters:

Command:       !:aaaa:bb:XXXXX:cc<CR>  
Response:       !:aaaa:bb::cc<CR>  
with:           aaaa = parameter address  
                 bb = quantity of payload in this telegram (00 – ff)  
                 cc = checksum: CRC8-CCITT:  $x^8 + x^2 + x^1 + 1 = 0x07$   
                 without cc and <CR>  
                 XXXX = bb-bytes payload

Response with an error message:

Answer:         !:aaaa:bb:XX:cc<CR>

Description of the response elements:

aaaa           parameter address,  
Bb             quantity of payload (always 02)  
cc             checksum: CRC8-CCITT:  $x^8 + x^2 + x^1 + 1 = 0x07$   
                 without cc and <CR>  
                 XX = 2 bytes error message (see table below)

Example of an unknown command:

Query:           ?:0005:00::cc<CR>  
Response:       !:0005:02:?1:cc<CR>

Meaning of the two bytes in the error message:

Error message	Description
?0	Error in telegram structure or checksum
?1	Unknown command or unknown parameter
?2	Internal memory error
?3	Data error (value not within its limits)

## Overview of general parameters (Addresses 0xxx)

General parameters are system values such as date, time, and the mainboard version number.

## Reading general parameters

Address	Description	Comment
0001	Mainboard version number	8 places
0010	Date and time display [hours:minutes:seconds]; [day:month:year]	17 bytes / decimal value In the format xx:xx:xx;xx:xx:xx
0011	Date [day:month:year]	8 bytes / decimal value In the format xx:xx:xx
0012	Time [hours:minutes:seconds]	8 bytes / decimal value In the format xx:xx:xx

## Overview of incubator parameters (Addresses 2xxx)

Incubator parameters are divided into:

- the basic parameters of the three control loops temperature, CO<sub>2</sub>, and O<sub>2</sub>,
- the internal function parameters of operating functions and data logging.

## Reading basic parameters

Address	Description	Comment
2000	Device status <sup>*1)</sup> (Error) Status of the control loops temperature, CO <sub>2</sub> , O <sub>2</sub> , RH, ref. temp.	33 bytes / hexadecimal value in the format xxxxxxxx;xxxx; ... ;xxxx;xxxx;xxxx
2010	Set, actual, and reference temperature <sup>*2)</sup>	23 bytes / decimal value in the format +xxx.xx;+xxx.xx;+xxx.xx
2020	Set and actual CO <sub>2</sub> level <sup>*2)</sup>	15 bytes / decimal value in the format +xxx.xx;+xxx.xx
2030	Set and actual O <sub>2</sub> level <sup>*2)</sup>	15 bytes / decimal value in the format +xxx.xx;+xxx.xx
204a	Actual water level (100% or 0%)	7 bytes / decimal value in the format +xxx.xx
204b	Low humidity indicator (1 active, 0 inactive)	2 bytes / hexadecimal in the format xx

\*1) Example of device status and (error) status, control loops  
(for details see error messages)

\*2) All values have two decimal places

## Reading internal function parameters

Address	Description	Comment
2100	Status of run <sup>*1)</sup> and remaining run time [hours:minutes] Disinfection, with date and time of last start	25 bytes / decimal value in the format xx;+xxx:xx;xx.xx.xx;xx:xx
2105	Status of run <sup>*1)</sup> , current CO <sub>2</sub> offset + waiting period [minutes:seconds] auto-start, with date and time of last start	25 bytes / decimal value in the format xx;xx.x;+xxx:xx;xx.xx.xx;xx:xx
2140	Read status of gas cylinder changeover switch CO <sub>2</sub> <sup>*3)</sup>	2 bytes / hexadecimal in the format xx
2141	Read status of gas cylinder changeover switch O <sub>2</sub> <sup>*3)</sup>	2 bytes / hexadecimal in the format xx
2300	Read out error log (current errors) <sup>*4)</sup>	Up to 241 bytes / hexadecimal value For format, see section on this topic
2301	Read out error log (older errors) <sup>*4)</sup>	Up to 241 bytes / hexadecimal value For format, see section on this topic
2400	Query (Start) of data stored in the data logger <sup>*5)</sup>	Up to 224 bytes / hexadecimal value For format, see section on this topic
2401	Query of other data stored in the data logger <sup>*6)</sup>	224 bytes / hexadecimal value For format, see section on this topic
2402	(Repeat) query for last data logger query <sup>*7)</sup>	224 bytes / hexadecimal value For format, see section on this topic
2410	Read out writing cycle of the data logger in hours/minutes/seconds	8 bytes / decimal value in the format xx:xx:xx

\*1) See table for notes on disinfection and auto-start run status.

\*2) Two bytes each per level.

\*3) Cylinder A active (0x01), cylinder B active (0x02), pressure in cylinder A OK (0x10), pressure in cylinder B OK (0x20).

\*4) Further information on the error log in section 13.5.

\*5) Set the read pointer to the first entry, read max. 7 entries.

\*6) Send the next 7 entries. Set the read pointer automatically to the nearest newer entry, read max. 7 entries.

\*7) Send entries from the last telegram again. Can be used when a communication error has occurred.

Note on \*3) Disinfection and auto-start run status:

Bit	Disinfection	Auto-start
0x00	Steri-Run not activated	Auto-start not activated
0x01	Initialization	Initialization
0x02	Wait until door opens	Wait until door opens
0x03	Wait until door closes	Wait until door closes
0x04	Start	Start
0x05	Heating	Heating
0x06	Holding	Perform reverse voltage calibration
0x07	Condensation	Waiting period 1
0x08	Cool-down	Set tolerance band
0x09	Dry	Establish stable humidity
0x0A	Wait for release	Perform reverse voltage calibration
0x0B	Abort	Waiting period 2
0x0C	-	Determine offset
0x0D	-	Read out and test offset
0x0E	-	Release
0x0F	-	Abort

## Error memory structure

The error memory contains 22 error messages. A query is answered with 22 data sets with a colon as separator and can be queried using the following commands:

Query:           ?:2300:00::cc<CR>  
Read the last 11 error memory entries.

Query:           ?:2301:00::cc<CR>  
Read the first 11 error memory entries.

These data sets consist of 11 bytes and are encrypted in 21 ASCII characters prior to data transmission. Example: The byte 0x23 is converted into the ASCII characters 0x32 ("2") and 0x33 ("3").

- Byte 1 consists of 1 character,
- Bytes 2 - 11 consist of 2 characters.



**Figure 12-46.** Error memory data set structure

The following information is transmitted in this data set:

- Created on 11 January 2006 at 15:55:34.
- A device error has occurred and the actual temperature is too high.

## Overview of the possible error messages in hex coding

Hex code	Description / Type
0x00	Temperature control loop
0x01	CO <sub>2</sub> control loop
0x02	O <sub>2</sub> control loop
0x07	Water level
0x08	General device status

## Overview of the possible error messages in bit coding General device Status, temperature and CO<sub>2</sub> control loop

Bit	General device status
0x0002	Device door open too long
0x0004	Display not communicating
0x0008	Mainboard parameter implausible (EEPROM faulty)
0x0010	Data logger defective (device remains functional)
0x0020	Error in disinfection / Steri-Run
0x0040	No power supply during Steri-Run
0x0080	Error in auto-start
0x0100	ADC test failed
0x0400	Fan error
0x1000	IR sensor system replaced (info)
0x2000	Auto-start active (info)
0x4000	Disinfection active (info)
0x8000	Device error has occurred (info)

Bit	Temperature control loop error status
0x0001	Sensor breakage
0x0002	Actual value high
0x0004	Actual value low
0x0008	Actual value not plausible
0x0010	Calibration values too high/low

Bit	CO <sub>2</sub> control loop error status
0x0001	Sensor breakage
0x0002	Actual value high

Bit	CO <sub>2</sub> control loop error status
0x0004	Actual value low
0x0010	Calibration values too high/low
0x0020	Error communication (to sensor)
0x0040	Error communication (to gas cylinder changeover switch)
0x0080	No gas available, cylinders A and B empty
0x0200	Gas cylinder A empty
0x0400	Gas cylinder B empty

## O<sub>2</sub> and water level control loop:

Bit	O <sub>2</sub> control loop error status
0x0001	Sensor breakage
0x0002	Actual value high
0x0004	Actual value low
0x0020	Error communication (to sensor)
0x0040	Gas cylinder changeover switch not communicating
0x0080	No gas available, cylinders A and B empty
0x0200	Gas cylinder A empty
0x0400	Gas cylinder B empty

Bit	Water level error status
0x0001	No water

## Data logger structure

The data logger stores up to 10,000 entries. Depending on the setting for the logging cycle (in sections of seconds), e.g. for a value of 10,000 s (default value), the events of about 5 days can be logged.

The data logger stores the following information:

- Important user actions, system events, and error messages.
- Measured data of the three control loops during incubation operation.

The data logger can be queried using the following commands:

Query:           ?:2400:00::cc<CR>

Set the data logger read pointer to the oldest entry and output of the first data sets.

Query:           ?:2401:00::cc<CR>

Output of the subsequent data sets; the read pointer automatically moves

gradually from the older entries to the current entries.  
Query: ? :2402:00::cc<CR>  
Repeated output of the most recently read data; this command does not move the read pointer.

This command can be used to avoid data loss after a communication error.

Each query command is answered with up to 7 data sets that follow one another without a separator. These data sets consist of 16 bytes and are encrypted into 32 ASCII characters prior to transmission.

For example, the byte 0x23 is converted into the ASCII characters: 0x32 ("2") and 0x33 ("3").

Therefore, a response consists of up to  $7 \times 16 = 112$  bytes, i.e. 224 ASCII characters. The date and time (without seconds), the device status, and the type of data logger entry are always transmitted in a data set (bytes 0-7, and ASCII characters 0-15). Also, depending on the entry, the current actual or set values of the control loops or other parameters can be entered (bytes 8-15 or ASCII characters 16-31).

Example of a response:

```
!:2400:e0:010b01060f3700000177002800d40000110b01060f3800000172003200d20352  
... ..:80
```

First data set     !:2400:e0:010b01060f3700000177002800d4000011  
                  (consisting of 32 byte ASCII characters)

Second data set   0b01060f3800000172003200d20352... ..:80  
                  (beginning of the second data set after 32 bytes of the first data set)

## Data logger data set structure scheme

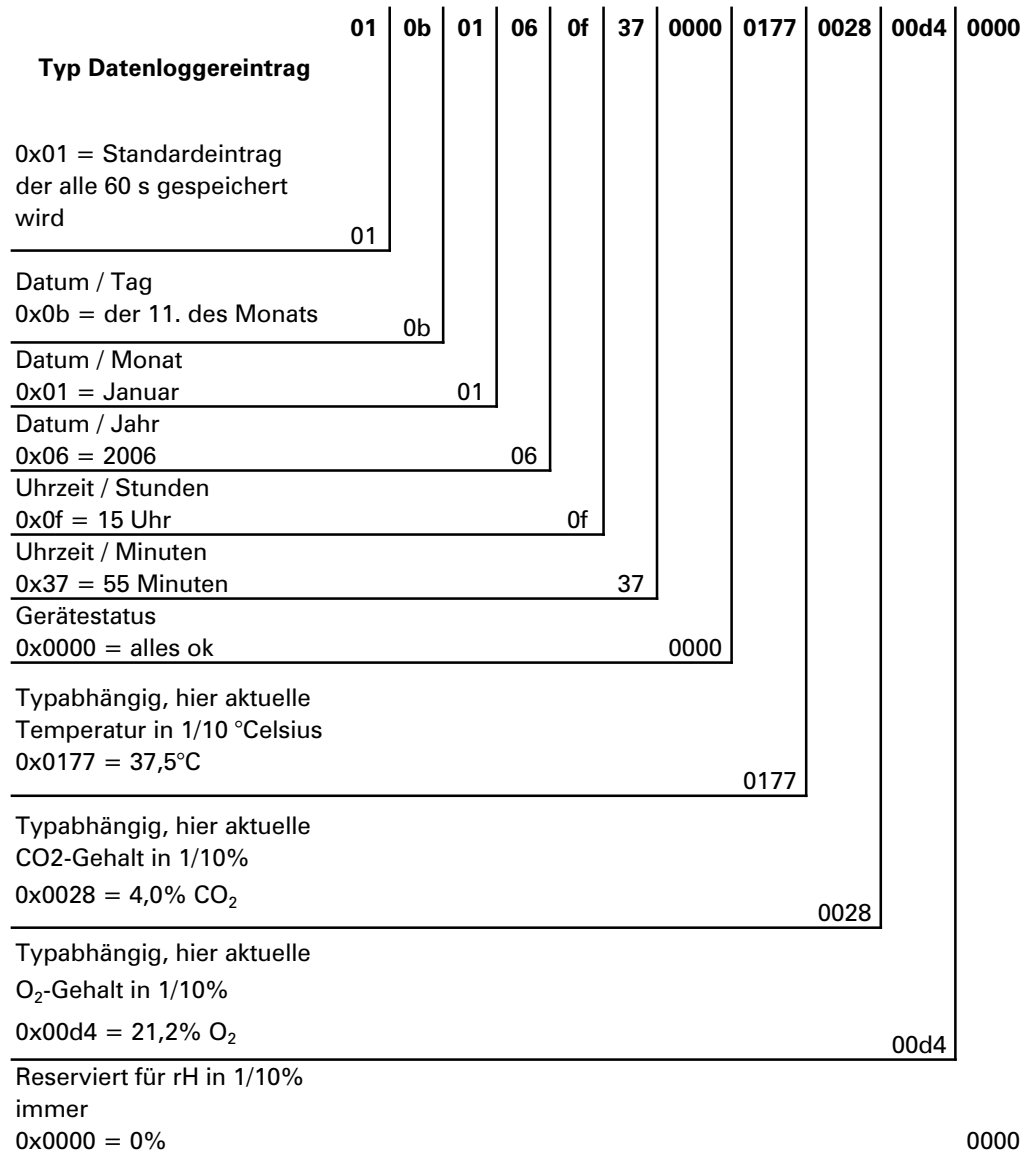

**Figure 12-47.** Data logger data set structure

The following information is transmitted in this data set:

- Created on 11 January 2006 at 15:55.
- The device status reports no anomalies.
- The temperature is 37.5°C.
- Gas concentration 4.0% CO<sub>2</sub>, 21.2% O<sub>2</sub>.

### Note

Code example

You will find an example of a code at the end of this chapter.

## Overview of possible event entries in bit coding

### Overview of event entries, part I:

Code	Event	Information (byte 8-15)
0x01	Set values from all control loops (periodically in one-minute cycles)	Current values for temperature, CO <sub>2</sub> , O <sub>2</sub> , and RH
0x02	Set value change (at the beginning of a new section)	Set value for temperature, CO <sub>2</sub> , O <sub>2</sub> , and RH
0x10	Temp set value changed	Set value for temperature, CO <sub>2</sub> , O <sub>2</sub> , and RH
0x11	CO <sub>2</sub> set value changed	Set value for temperature, CO <sub>2</sub> , O <sub>2</sub> , and RH
0x12	O <sub>2</sub> set value changed	Set value for temperature, CO <sub>2</sub> , O <sub>2</sub> , and RH
0x20	New error T	Status/error registration for temperature, CO <sub>2</sub> , O <sub>2</sub> , and RH
0x21	New error CO <sub>2</sub>	Status/error registration for temperature, CO <sub>2</sub> , O <sub>2</sub> , and RH
0x22	New error O <sub>2</sub>	Status/error registration for temperature, CO <sub>2</sub> , O <sub>2</sub> , and RH
0x2F	New error system	Status/error registration for temperature, CO <sub>2</sub> , O <sub>2</sub> , and RH
0x30	Power reset	Set value for temperature, CO <sub>2</sub> , O <sub>2</sub> , and RH
0x31	Lid open	Current actual values for temperature, CO <sub>2</sub> , O <sub>2</sub> , and RH
0x32	Door closed	Current actual values for temperature, CO <sub>2</sub> , O <sub>2</sub> , and RH
0x40	Customer temperature calibration	Calibration level (2 bytes), old temperature, new temperature (2 bytes each)
0x41	Customer CO <sub>2</sub> calibration	Calibration level (2 bytes), old CO <sub>2</sub> value, new CO <sub>2</sub> value (2 bytes each)
0x42	Customer O <sub>2</sub> calibration	Calibration level (2 bytes), old O <sub>2</sub> value, new O <sub>2</sub> value (2 bytes each)
0x50	Start of auto-start	Status/error registration for temperature, CO <sub>2</sub> , O <sub>2</sub> , and RH
0x51	Auto-start successfully completed	Current actual values for temperature, CO <sub>2</sub> , O <sub>2</sub> , and RH

## Overview of event entries, part II:

Code	Event	Information (byte 8-15)
0x52	Auto-start completed with error	Status/error registration for temperature, CO <sub>2</sub> , O <sub>2</sub> , and RH
0x53	Auto-start stopped manually	Status/error registration for temperature, CO <sub>2</sub> , O <sub>2</sub> , and RH
0x60	Start of Steri-Run	Status/error registration for temperature, CO <sub>2</sub> , O <sub>2</sub> , and RH
0x61	Steri-Run successfully completed	Current actual values for temperature, CO <sub>2</sub> , O <sub>2</sub> , and RH
0x62	Steri-Run completed with error	Status/error registration for temperature, CO <sub>2</sub> , O <sub>2</sub> , and RH
0x63	Steri-Run stopped manually	Status/error registration for temperature, CO <sub>2</sub> , O <sub>2</sub> , and RH
0x90	Low humidity start	Current actual values for temperature, CO <sub>2</sub> , O <sub>2</sub> , and RH
0x91	Low humidity stop	Current actual values for temperature, CO <sub>2</sub> , O <sub>2</sub> , and RH
0xe0	Deletion of data logger	Current actual values for temperature, CO <sub>2</sub> , O <sub>2</sub> , and RH
0xff	Last entry of data logger	No information, not even on date, time, and status

## Examples of data logger codes

An entry in the data logger is 16 bytes in size and has the following structure:

- 1st byte: indicates the event (e.g. door open 0x31, measured value entry 0x01)
- 2nd byte: day of the entry
- 3rd byte: month
- 4th byte: year
- 5th byte: hour
- 6th byte: minutes
- 7th and 8th bytes: device status
- 9th to 16th bytes: various data about the event

## Functions for data logger query

The following code example for reading the data logger uses six functions:

- `ahex`  
// converts the received ASCII character into a hexadecimal number,
- `send_telegramm`  
// sends a query to the data logger,

- `get_telegramm`  
// receives a response from the data logger,
- `time_2_str`  
// uses a hexadecimal value to create ASCII characters in time format,
- `num_2_string`  
// uses hexadecimal values to create ASCII characters to be entered into a file,
- `read_datalogger`  
// processes the received data and writes them into a file.

## Example of a code for a data logger query

### char ahex (char a)

```
char ahex(char a)
{
    char i;
    char hexa[16]="0123456789abcdef";

    for (i = 0; i < 16; i++)
        if (a == hexa[i])
            return (i);
    return 0;
}
```

### send\_telegram

```
void send_telegram(char *p)
{
    char string [15];
    unsigned char bcc = 0xFF;
    char i;

    // copy telegram together
    strncpy (&string[0], „?:xxxx:00::00\r“, 14);
    // insert 4-digit address
    strncpy (&string[2], p, 4);
    // calculate checksum: inverted XOR of all bytes
    // without checksum and <CR>
    for (i = 0; i < 11; i++)
        bcc = (bcc^string[i]);
    // copy checksum
    string[11] = hexa(bcc/16);
    string[12] = hexa(bcc%16);
    // send telegram
    ComWrt (COM_NR, string, 14);
    return;
}
```

## get\_telegram

```
int get_telegram(char *p)
{
    int reading_count = 0;
    // reading the telegram character by character
    do
        ComRd(COM_NR, &p[reading_count], 1);
    // until receipt of <CR>
    while ((p[reading_count++] != '\r'));
    // return = number of received characters
    return (reading_count);
}
```

## time\_2\_str

```
char time_2_str (int z, char * b)
{
    char i;
    // issue two numerals
    for (i = 1; i >= 0; i--){
    //calculate value
        b[i] = z%10+0x30;
    // reduce default value
        z = z/10;
    }
    return (2);
}
```

## num\_2\_string

```
char num_2_str (int z, char * b)
{
    // number with one decimal place
    char a[12];
    char i, l;
    int rest = 0;
    l = 0;
    // Negative number?
    if (z < 0) {
    // set algebraic sign
        b[0] = '-'; l = 1;
    // convert value
        z = 0xffffffff-z+1;
    }
    // save decimal place
    rest = z % 10;
    // cut off decimal place
    z = z / 10;
    // calculate and copy number before decimal separator
    for (i = 0; i < 12; i++){
    // calculate value
        a[i] = z%10+0x30;
    // reduce default value
        z = z/10;
    }
}
```

```
// number copied completely?  
    if (z == 0) break;  
    }  
    for ( ; i >= 0; i--)b[l++] = a[i];  
// calculate and copy number after decimal separator  
    b[l++] = ',';  
// calculate value  
    b[l++] = rest%10+0x30;  
    return (l);  
}
```

## read\_datalogger

```
int read_datalogger ()  
{  
#define SIZE_DATA2 16  
#define EVENT_STATUS 0x01  
unsigned char buffer[300], string [300];  
unsigned char numberstring [150], datestring, timestring;  
unsigned char excelstring [150];  
unsigned char len, h,i;  
unsigned int read_count,status;  
#define EVENT_DATA.END 0xFF  
char data;  
int GetTele = 0  
GetError = 0,  
// writing the title line in the file  
WriteFile (FileHandle, "Date;Time;Comment;Temp Act.;CO2 Act.;O2  
Act.;rH Act.;Temp Set;CO2 Set;O2 Set;rH Set;\n", 85);  
// infinite loop  
while (1)  
    {  
// set data logger to beginning and read  
    if (!GetTele) {  
        send_telegram ("2400");  
    }  
    else{  
// read additional data sets  
        send_telegram ("2401");  
    }  
    len = get_telegram (buffer);  
// no telegram received  
    if (!len) {  
        GetError ++;  
// requery  
        send_telegram ("2402");  
        len = get_telegram (buffer);  
// no telegram received again  
        if (!len) return 1;  
    }  
// increase telegram counter  
    GetTele ++;  
// length of sent payload
```

## Data communication

Examples of data logger codes

```
len = (ahex(buffer[7]) * 0x10 + ahex(buffer[8])) / 2;
// converting ASCII string into usable number string
for (i = 0; i < (string); i++)
    number string [i] = (ahex(buffer[10 + (2*i)]) * 0x10 +
    ahex(buffer[11 + (2*i)]));
// calculation of the sent data packets
data = ((len) / SIZE_DATA2);
// evaluation of all data packets
for (i = 0; i < data; i++){
    len = 0;
// write time and date into file
    len += time_2_str (number string[1+i*SIZE_DATA2],
    &excelstring[len]);
    excelstring[len ++] = '.';
    len += time_2_str (numberstring[2+i*SIZE_DATA2],
    &excelstring[len]);
    excelstring[len ++] = '.';
    len += time_2_str (numberstring[3+i*SIZE_DATA2],
    &excelstring[len]);
    excelstring[len ++] = '.';
    len += time_2_str (numberstring[4+i*SIZE_DATA2],
    &excelstring[len]);
    excelstring[len ++] = '.';
    len += time_2_str (numberstring[5+i*SIZE_DATA2],
    &excelstring[len]);
    excelstring[len ++] = '.';
    len += time_2_str (0, &excelstring[len]);
    excelstring[len ++] = '.';

    switch (numberstring[i*SIZE_DATA2]){
        case EVENT_STATUS:
//check cyclic entries for device errors
        status = numberstring[6+i*SIZE_DATA2]*0x100+
        numberstring[7+i*SIZE_DATA2];
        if (status & INFO_ERROR){
            str_cpy (&excelstring[len], "Error active;", 13);
            len += 13;
        }
        else{
// query all device errors (see "Overview of possible event entries in bit coding Overview
of event entries, part I:" on Page 12-15)
            if (status & DOOR_LONG){
                str_cpy (&excelstring[len], "Door open too long;",
                19);
                len += 19;
            }
            else {
                if (status & DOOR_OPEN){
                    str_cpy (&excelstring[len], "Door open;", 10);
                    len += 10;
                }
            }
        }
// query remaining device errors now
//      .
//      .
//      .
```

```

//      .
//      .
//and finally query cyclic actual value entry without device errors
//query

else{
    str_cpy (&string[string], "ok;", 3);
    string += 3;
}
}
// copy actual values from number string to excel string
len += num_2_str ((numberstring[8+i*SIZE_DATA2]*0x100+
numberstring[9+i*SIZE_DATA2]), &excelstring[len]);
excelstring[len++] = ',';
len += num_2_str ((numberstring[10+i*SIZE_DATA2]*0x100+
numberstring[11+i*SIZE_DATA2]), &excelstring[len]);
excelstring[len++] = ',';
len += num_2_str ((numberstring[12+i*SIZE_DATA2]*0x100+
numberstring[13+i*SIZE_DATA2]), &excelstring[len]);
excelstring[len++] = ',';
len += num_2_str ((numberstring[14+i*SIZE_DATA2]*0x100+
numberstring[15+i*SIZE_DATA2]), &excelstring[len]);
excelstring[len++] = ',';
// enter set values from here
len += num_2_str (SetTemp, &excelstring[len]);
excelstring[len++] = ',';
len += num_2_str (SetCO2, &excelstring[len]);
excelstring[len++] = ',';
len += num_2_str (SetO2, &excelstring[len]);
excelstring[len++] = ',';
len += num_2_str (SetRH, &excelstring[len]);
excelstring[len++] = ',';
excelstring[len] = '\n';
len += 1;
WriteFile (FileHandle, excelstring, len);
break;
// query the remaining events from here
case EVENT_FORMAT_DATALOG:
    WriteFile (FileHandle, excelstring, len);
    WriteFile (FileHandle, "Data logger erased;\n",20);
    break;
case EVENT_POWER_ON:
// update of set values
SetTemp = numberstring [8+i*SIZE_DATA2]*0x100+
numberstring[9+i*SIZE_DATA2];
SetCO2 = numberstring[10+i*SIZE_DATA2]*0x100+
numberstring[11+i*SIZE_DATA2];
SetO2 = numberstring[12+i*SIZE_DATA2]*0x100+
numberstring[13+i*SIZE_DATA2];
SetRH = numberstring[14+i*SIZE_DATA2]*0x100+
numberstring[15+i*SIZE_DATA2];
WriteFile (FileHandle, excelstring, len);
WriteFile (FileHandle, "Power on;\n", 10);

```

```
        break;
    case..
// query all events here (see "Overview of possible event entries in bit coding Overview of
event entries, part I:" on Page 12-15)
// cancel 0xFF indicates the end of the data logger
    case 0xFF:
        WriteFile (FileHandle, "End;\n",5);
    }
}
return 0;
}
```

## Vios iDx 165/255 program

The program provides a user interface (only with English menu names) for handling data communication between the device and a connected PC.

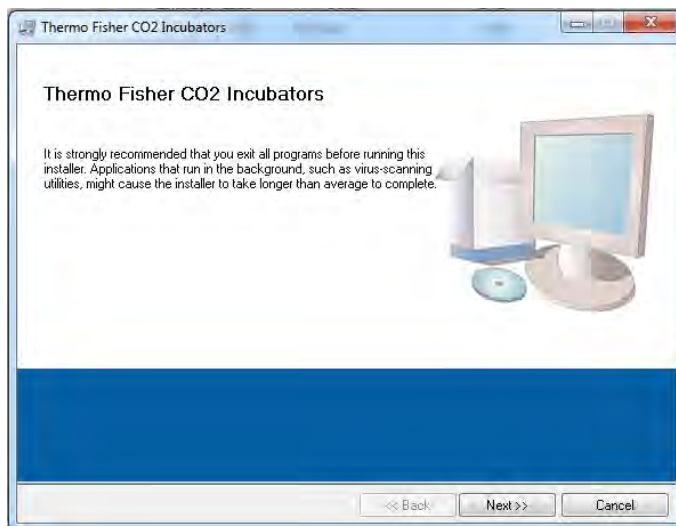

**Figure 12-48.** Vios iDx 165/255 program

This program is used for:

- Reading and archiving error messages (error logger). The data sets are saved in the \*.CSV metaformat.
- Reading and archiving event entries (data logger). The data sets are saved in the \*.CSV metaformat.
- Creating a service file (servicefile) to be sent to the Thermo Fisher Scientific Technical Service. The information of the service file is used for systematic troubleshooting. The data sets are saved in the proprietary format \*.SRF:

## Installing Vios iDx 165/255

1. On the data CD in the subdirectory PROGRAMS, double click on the file SETUP.EXE to start the installation routine.

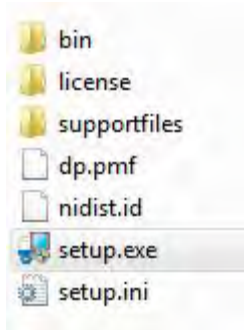

**Figure 12-49.** Installing Vios iDx 165/255 program - 1

2. Define the installation directory for the program.

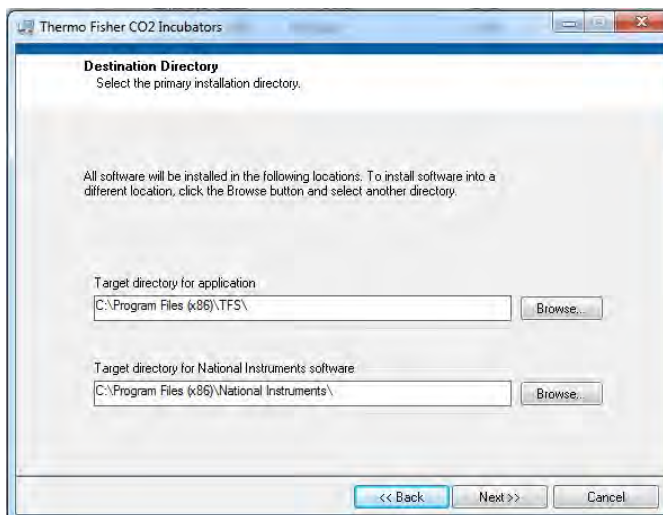

**Figure 12-50.** Installing Vios iDx 165/255 program - 2

3. Perform the following steps in sequence:
  - a. Confirm the license agreement
  - b. Confirm the scope of installation
  - c. After the "installation complete" message has been issued, close the installation interface and restart the computer.

## Using Vios iDx 165/255

### Layout of the user Interface

The user interface is organized into two main menus:

- MAIN with two functional elements:
  - Program version issue: FIRMWARE VERSION
  - Switch for exiting the program: QUIT

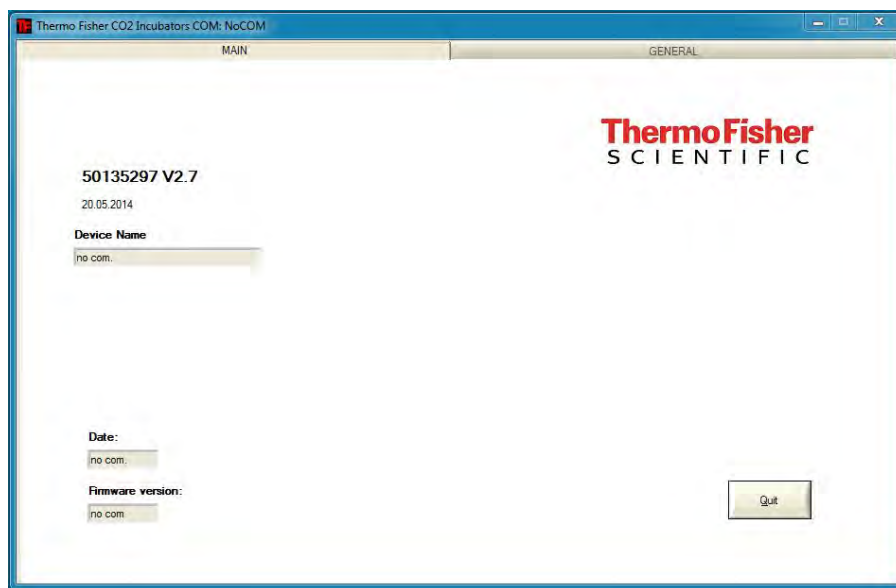

**Figure 12-51.** Vios iDx 165/255 user interface - 1

- GENERAL with the submenus:
  - PRESETTING for setting the transmission speed and for selecting the serial port,
  - TEST COM for testing the communication connection between PC and incubator,
  - DATE & TIME for setting date and time to the desired time zone,
  - ERROR LOGGER for reading the error messages,
  - DATA LOGGER for reading the event entries,
  - SERVICEFILE for reading error information and for creating a service file,
  - PASSWORD to block access to the device parameters of the incubator.

## User menu function

### PRESETTING

The submenu PRESETTING is used to set the transmission speed and to select the serial port.

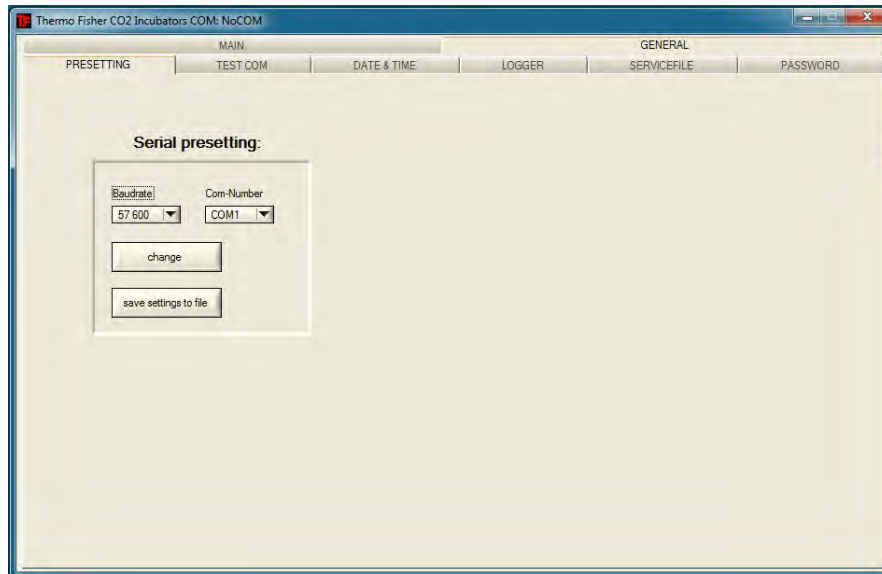

**Figure 12-52.** Vios iDx 165/255 user interface - 2

4. Select the PC serial port. Once the USB driver is installed, you can select the (virtual) COM port assigned to the USB connection (see "[USB interface](#)" on [Page 12-1](#)).
5. Apply the settings by pressing the "Change" key.
6. Save the settings in an .ini file by pressing the "SAVE TO FILE" key.

#### Note

##### Transmission speeds

The transmission speed settings in the PRESETTING user menu must be identical to those of the device.

## TEST COM

The TEST COM submenu is used for testing the communication connection with the settings defined in the PRESETTING submenu.

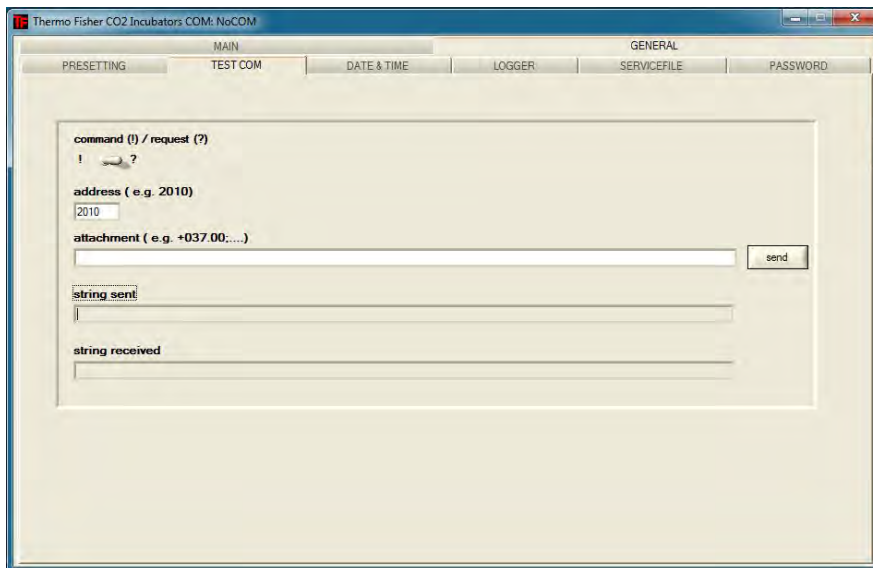

**Figure 12-53.** Vios iDx 165/255 user interface - 3

Example of a query for the currently measurable temperature values of the incubator:

- Query: ? (default, not changeable)
- Address: 2010 (Address temperature value: set value, actual value, reference value)

1. Send the query to the incubator:
  - a. Press the "SEND" key.

If the incubator returns a response string, the communication connection to the incubator has been established.

If a connection cannot be established, an error dialog is displayed:

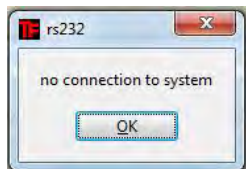

**Figure 12-54.** Vios iDx 165/255 user interface - 4

- b. Close the error dialogue by pressing the "OK" key.

## DATE & TIME

The DATE & TIME submenu is used for setting date and time to the desired time zone.

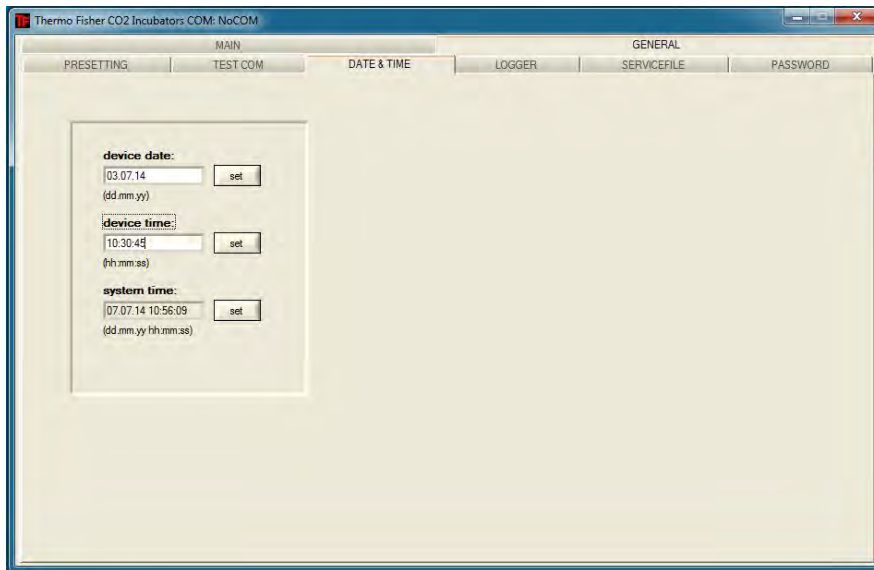

Figure 12-55. Vios iDx 165/255 user interface - 5

Data in the two text boxes must be entered in the format DD.MM.YY (day, month, year).

- Apply the entry by pressing the “Set” key.

## ERROR LOGGER

The ERROR LOGGER submenu is used for importing the error messages into the text box of the user surface.

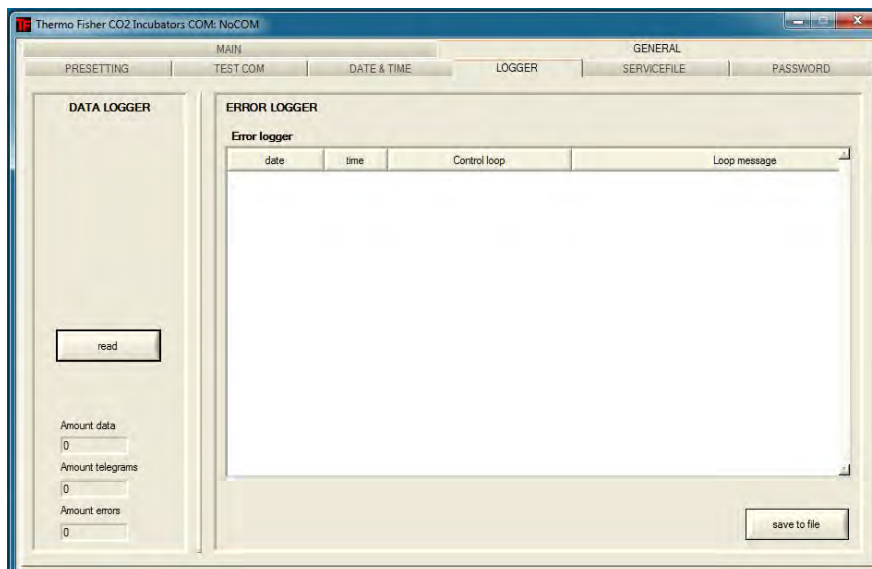

Figure 12-56. Vios iDx 165/255 user interface - 6

The data sets can be saved in the \*.CSV metaformat.

- Save the data records as a file by pressing the “SAVE TO FILE” key.

## DATA LOGGER

The DATA LOGGER submenu is used for importing the event entries into the text box of the user interface.

The data sets are saved in the \*.CSV metaformat.

- Import the data sets by pressing the “READ” key.

The progress of the data transmission is indicated in the three text boxes:

- AMOUNT DATA: Total number of transmitted data sets
- AMOUNT TELEGRAM: Number of telegrams transmitted.
- AMOUNT ERRORS: Number of error messages transmitted.

### Note

Duration of data transmission:

As the data logger can contain up to 10,000 data sets, the data transmission to a PC may take some time.

## SERVICEFILE

The SERVICEFILE submenu is used for importing incubator error information and for creating a service file from it, saved with the proprietary extension \*.srf. The service file is transmitted to the Thermo Fisher Scientific Technical Service for fault analysis.

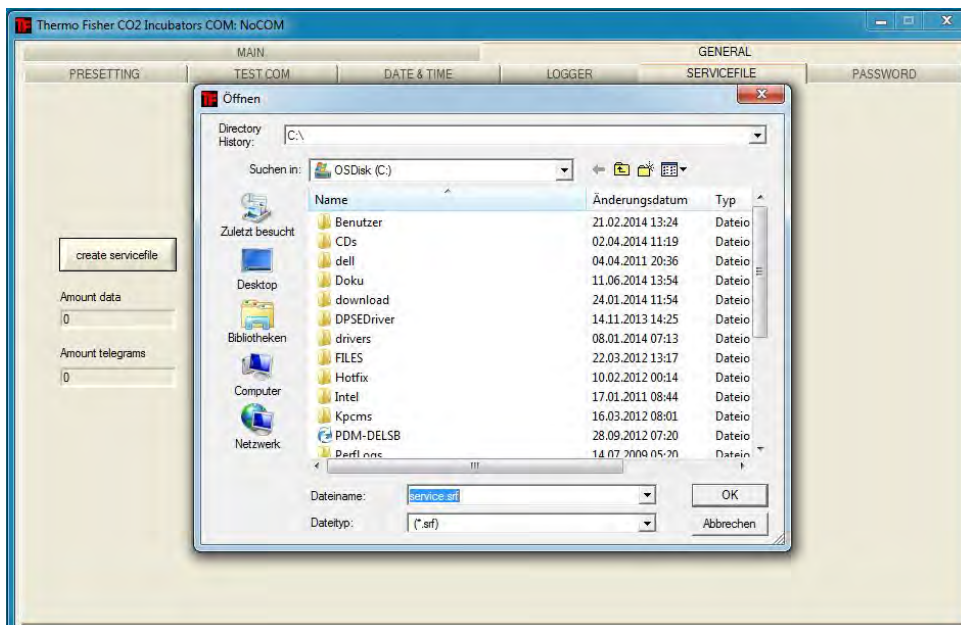

Figure 12-57. Vios iDx 165/255 user interface - 7

1. Create a service file by pressing the “CREATE SERVICEFILE” key.
2. Define the file name and save directory in the Windows dialog window.

3. Start the save process by pressing the “OK” key.

### Note

Duration of creation

The compilation of device information and the creation of the service file may take some time.

## PASSWORD

The PASSWORD submenu can only be accessed by the service personnel of Thermo Fisher Scientific.

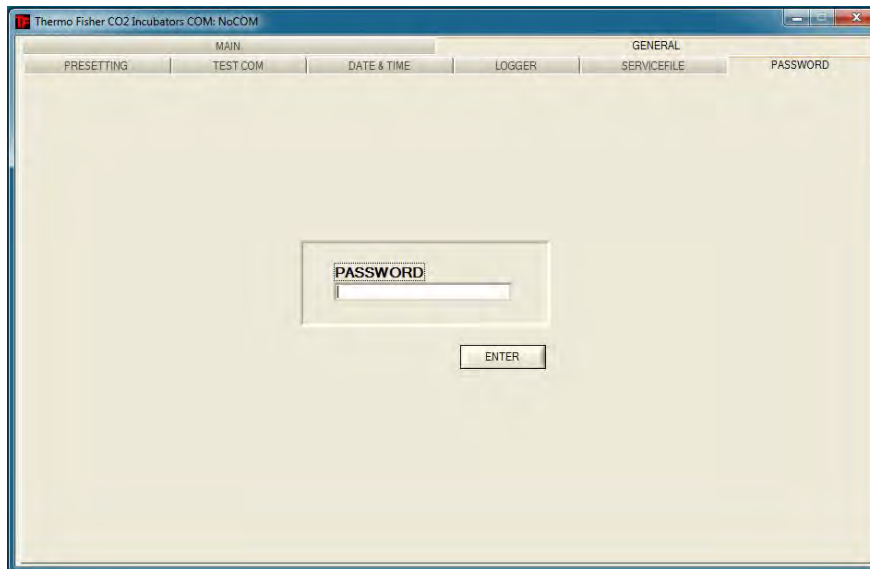

Figure 12-58. Vios iDx 165/255 user interface - 8



## Thermo Scientific Contact Information

### **Overview of the international Thermo Fisher sales organizations**

#### **Mailing address in Germany:**

Thermo Electron LED GmbH  
Robert-Bosch-Straße 1  
D-63505 Langenselbold

#### **Inquiries from Germany:**

Phone Sales 0800 1 536376  
Phone Service 0800 1 112110  
Fax Sales/Service 0800 1 112114  
Email [info.labequipment.de@thermofisher.com](mailto:info.labequipment.de@thermofisher.com)  
Helpdesk email: [service.lpg.germany.de@ThermoFisher.com](mailto:service.lpg.germany.de@ThermoFisher.com)

#### **Inquiries from Europe, Middle East and Africa:**

Tel. +49 (0)6184 / 90-6940  
Fax: +49 (0)6184 / 90-7474  
Email [info.labequipment.de@thermofisher.com](mailto:info.labequipment.de@thermofisher.com)

#### **Mailing address USA:**

Thermo Scientific  
275 Aiken Road  
Asheville, NC 28804  
USA

#### **Inquiries from North America:**

Phone +1 800-879 7767 +1 800-879 7767  
Fax +1 828-658 0363  
Email: [info.labequipment@thermofisher.com](mailto:info.labequipment@thermofisher.com)

#### **Inquiries from Latin America:**

Phone +1 828-658 2711  
Fax +1 828-645 9466  
Email: [info.labequipment@thermofisher.com](mailto:info.labequipment@thermofisher.com)

#### **Inquiries from Asia Pacific:**

Phone +852-2711 3910  
Fax +852-2711 3858  
Email: [info.labequipment@thermofisher.com](mailto:info.labequipment@thermofisher.com)

**Written inquiries from USA:**

Thermo Scientific  
275 Aiken Road  
Asheville, NC 28804  
USA

**Inquiries from USA/Canada**

**Sales:**+1 866 984 3766  
**Service:**+1 800 438 4851

**Inquiries from Latin America**

**Sales:**+1 866 984 3766  
**Service:**+1 866 984 3766

**Inquiries from Asia:**

**China**

**Sales:**+86 10 8419 3588  
**Service:**Toll-free 8008105118  
Support Mobile 4006505118 or +86 10 8419 3588

**India**

**Sales:**+91 22 6716 2200  
**Service:**Toll-free 1 800 22 8374 or +91 22 6716 2200

**Japan**

**Sales:**+81 45 453 9220  
**Service:**+81 45 453 9224

**Inquiries from the rest of Asia/Australia/New Zealand**

**Sales:**+852 2885 4613  
**Service:**+65 6872 9720

**Inquiries from countries not listed / rest of EMEA**

**Sales:**+49 6184 90 6940 or +33 2 2803 2000  
**Service:**+49 6184 90 6940

**Inquiries from Europe:**

**Austria**

**Sales:**+43 1 801 40 0  
**Service:**+43 1 801 40 0

**Belgium**

**Sales:**+32 53 73 4241  
**Service:**+32 53 73 4241

**Finland/Nordic/Baltic countries**

**Sales:**+358 9 329 100  
**Service:**+358 9 329 100

**France**

**Sales:**+33 2 2803 2180  
**Service:**+33 825 800 119

**Germany:**

**Mailing address in Germany:**

Thermo Electron LED GmbH  
Robert-Bosch-Straße 1  
D-63505 Langenselbold

**Phone**

**Sales** Toll-free 0800 1 536 376

or +49 6184 90 6940

**Service** Toll-free 0800 1 112110

or +49 6184 90 6940

**Email** info.labequipment.de@thermofisher.com

**Italy**

**Sales** +39 02 95059 341

**Service**+39 02 95059 250

**Netherlands**

**Sales** +31 76 579 5555

**Service**+31 76 579 5639

**Russia/CIS**

**Sales** +7 812 703 4215

**Service**+7 812 703 4215

**Spain/Portugal**

**Sales** +34 93 223 0918

**Service**+34 93 223 0918

**Switzerland**

**Sales** +41 61 716 7755

**Service**+41 61 716 7755

**England/Ireland**

**Service**+44 870 609 9203

**Sales** +44 870 609 9203

© 2024 Thermo Fisher Scientific Inc. All rights reserved. All trademarks are the property of Thermo Fisher Scientific Inc. and its subsidiaries. Specifications, conditions, and prices are subject to change. Not all products are available in all countries. Please consult your local sales representative for details.

Find out more at [thermofisher.com](https://www.thermofisher.com)

**thermo**scientific

## Appendix

### Sixfold segmented inner door for Cell Locker

The six-segment inner door for Cell Locker divides the existing interior of the CO<sub>2</sub> incubator into six individual workspaces (Cell Locker). Glass doors (access openings) are embedded in the front section for the removal of cultures. These can be opened and closed separately.



**Figure 14-1.** Sixfold segmented inner door for *CELL LOCKER*

#### Note

Device performance change

Due to the design of the sixfold segmented inner door, the performance data of the incubator change (see „Specifications” on page 11-1).

## Installing the insert shelves

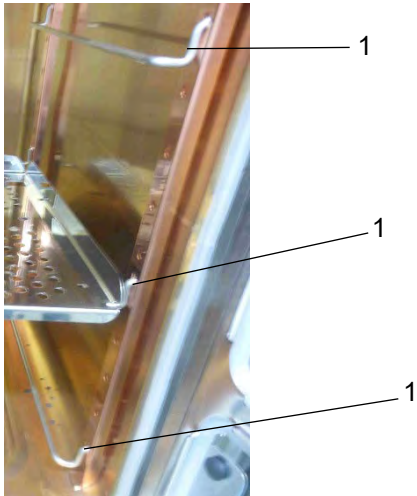

**Figure 14-2.** Inserting the support brackets

1. Insert the support brackets (1) in the lower, middle and upper rectangular holes of the support rails.
2. Insert the perforated shelves at the top and in the middle with continuous guide rails.

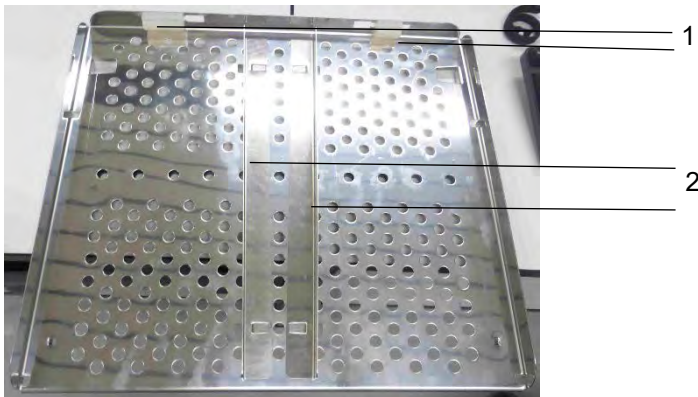

**Figure 14-3.** Perforated shelf with continuous guide rails

### Note

Do not remove the silicone plugs (1).

3. Insert the guide rails (2).

### Note

The guide rails can be removed if necessary.

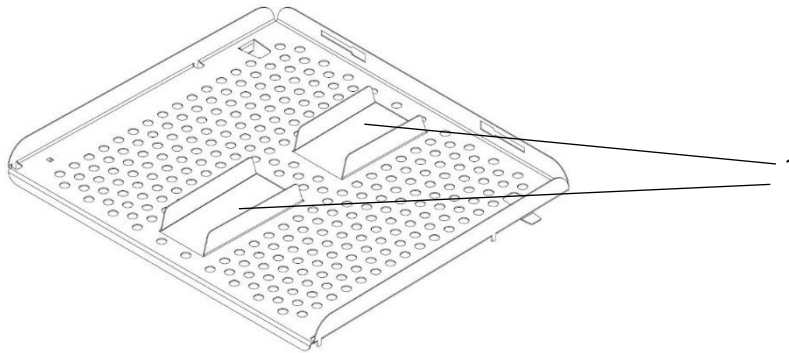

**Figure 14-4.** Perforated shelf with divided guide rails (below)

4. Insert the perforated shelf with the divided guide rails (Fig. 14-4, 1) and central openings at the bottom.



**Figure 14-5.** Installing the perforated metal shelf

5. Make sure that the perforated metal shelves lock in place behind the rail. The metal tab underneath the shelf needs to be fixed behind the rail so that the door closes.

**Note**

These guide rails cannot be removed.

6. Close the sixfold segmented inner door.